

APPLICATION AND INSTALLATION GUIDE

AIR INTAKE SYSTEMS

CATERPILLAR[®]

Contents

Air Intake Systems	
Air Cleaners	2
Standard Air Cleaners	2
Heavy-Duty Air Cleaners	3
Precleaners	3
Dual Element Air Cleaners	3
Exhaust Ejector	3
Oil-Bath Air Cleaners	4
Remote Mounted Air Cleaners	4
Customer Furnished Air Cleaners	5
Air Cleaner Efficiency	5
Air Cleaner Design Requirements	6
Air Cleaner Dust Calculation	6
Combustion Air Flow Requirements.....	8
Air Intake Ducting	9
General	9
Marine Intake Air Piping Examples	10
Air Inlet Adapters	14
Connections to Inlet Adapters and Turbochargers	14
Joining Two Turbochargers	16
Turbocharger Loading	17
Flex Connections	18
Cleanliness During Installation	18
Inlet Air Duct Insulation	19

Air Intake Restriction	19
Example	20
Additional Considerations	21
Service Indicators.....	21
Trip Lock Device	21
Differential Pressure Gauge	21
Intake Air Silencers	21
Air Inlet Shut Off	21
Air Manifold Drain Valve	22
Shielding	22
Breakaway Joints.....	22
Cold Conditions	22
Air Cleaner Icing	22
Boost Control	23
Extreme Cold	23
Considerations for Low Pressure Gas	23
Controlling Air Temperature.....	24
Gas-to-Air Heat Exchanger	25
Reference Material	26

Foreword

This section of the Application and Installation Guide generally describes wide-ranging requirements and options for the Air Intake System on Caterpillar® engines listed on the cover of this section. Additional engine systems, components and dynamics are addressed in other sections of this Application and Installation Guide.

Engine-specific information and data are available from a variety of sources. Refer to the Introduction section of this guide for additional references.

Systems and components described in this guide may not be available or applicable for every engine. Below is a listing of air intake system components for various Caterpillar engines. Refer to the Price List for specific options and compatibility.

<ul style="list-style-type: none"> ● = Standard ○ = Optional - = Not Available 	3126B	C7	C-9	C9	C-10/C-12	C11/C13	3406E	C-15/C-16	C15/C18	3412E	C27/C32	3500	C175	3600	G3300/G3400	G3500	G3520C	G3600
Standard Duty Air Cleaners	○	○	○	○	○	○	○	○	○	○	○	●	●	○	●	●	●	●
Heavy Duty Air Cleaners	○	○	○	○	○	-	○	○	-	○	○	○	-	○	-	-	-	○
Precleaners	○	○	○	○	○	○	○	○	-	○	○	○ [†]	○	○	○	-	-	-
Dual Element Air Cleaners	○	○	○	○	○	○	○	○	○	○	○	● [†]	○	-	-	-	○	-
Exhaust Ejectors	○	-	○	○	○	-	○	○	-	○	○	-	-	-	-	-	-	-
Remote Mounted Air Cleaners	-	-	-	-	-	-	-	-	-	-	-	○	○	●	-	-	●	●
Service Indicator, Trip Lock Device	○	○	○	○	○	○	○	○	○	○	○	●	●	●	●	●	●	●
Service Indicator, Differential Pressure Gauge	-	-	-	-	-	-	-	-	-	-	-	○ [†]	●	●	-	-	-	-
Intake Air Silencers	-	-	-	-	-	-	-	-	-	-	-	-	-	○	-	-	-	-
Inlet Air Shutoff	-	-	-	-	-	-	-	-	-	-	-	○ [†]	○	●	-	-	-	-
Air Manifold Drain Valve	-	-	-	-	-	-	-	-	-	-	-	-	○	○	-	-	-	-
Cold Weather Boost Control Valve	-	-	-	-	-	-	-	-	-	-	-	-	-	○	-	-	-	-

† Standard on select models, Optional on others.

‡ Optional on select models, Not Available on others.

Information contained in this publication may be considered confidential. Discretion is recommended when distributing. Materials and specifications are subject to change without notice.

CAT, CATERPILLAR, their respective logos, "Caterpillar Yellow" and the POWER EDGE trade dress, as well as corporate and product identity used herein, are trademarks of Caterpillar and may not be used without permission.

Air Intake Systems

A well designed air intake system provides cool, clean air for combustion while minimizing inlet air pressure drop to the turbocharger. Normally, this can be accomplished by using engine-mounted air cleaners, but some applications require intake air to be brought in through ducts from outside the engine room. There may also be requirements for special filtration and ducting due to fumes, dust, airborne mists, ambient temperature or even altitude. These requirements should be carefully considered because the inlet restriction that accompanies increased filtration and ducting can cause the engine to be derated and turbocharger life reduced. The air inlet restriction limits shown in TMI must not be exceeded, especially for EPA certified engines, in order to ensure regulatory compliance.

Air intake systems using ducted air from outside the engine room should be accessible for routine maintenance and inspection. The system should also be located away from exhaust stacks (including engine exhaust stack), vents or processes that might vent flammable vapors, large concentrations of dirt, chemicals, industrial waste, or any other material that would not allow for cool, clean air. In an optimal design, nominal air temperature around the inlet should be between 15° to 32°C (60° to 90°F). Inlet air temperatures should not exceed 45°C (113°F) for standard ratings.

For all Caterpillar engines, efficient engine combustion is based on the proper mass flow ratio of fuel and air. The ratio is mass-based and not volume-based. It is always important to remember this fact when considering the impact of installations with non-standard altitude and temperature. Also be sure to submit a special rating request for non-standard altitude and temperature applications so it can be evaluated by Caterpillar performance engineering.

SECTION CONTENTS

Air Cleaners..... 2	• Connections
• Dust, Dirt & Debris	• Insulation
• Types of Air Cleaners	• Intake Air Restriction
• Customer Furnished Air Cleaners	Additional Considerations 20
Combustion Air Requirements 8	• Service Indicators
Air Intake Ducting 9	• Silencers
• General	• Shutoff Valve
• System Design	• Cold Weather Operation
• Inlet Adapters	• Low Pressure Gas Engines
• Turbocharger Loading	• Reference Material 25

Air Cleaners

Dirt and debris are the major source of engine wear. For this reason, air cleaners are necessary to remove dirt and debris from the incoming air. Any moving engine part may be subjected to accelerated wear when dirt is contained in the inlet air. Since the air intake is one of the primary locations where dirt may enter an engine, frequent replacement of air cleaners may be needed.

Dirt and debris is introduced into the intake air ducting through:

- Residual materials from initial fabrication and assembly of the intake air ducts.
- Filter changes.
- Leaks in the ducting system.
- Intake air flow.

Engine wear tests have shown that dust particles under 1 micron (0.00004 in.) size have little effect on the engine. 99.5% of this dust will pass out through the engine exhaust.

Dust particles 1 to 10 microns (0.00004 to 0.0004 inch) in size has a measurable effect on engine life. Inlet air dust particles larger than bearing oil film thicknesses will seriously affect bearing and piston ring life.

Well designed air cleaners are the most efficient way of assuring that only clean air enters the engine and harmful particles are not distributed through the engine systems.

The efficiency of dry-type filters is not affected by installation

orientation. However, special care should be used in arranging the filter housing and piping to ensure that dirt retained in the filter housing is not inadvertently dumped into the engine air supply during air cleaner service. A vertically mounted air cleaner with a bottom-mounted engine supply pipe is particularly vulnerable to this occurrence. A filter design incorporating a secondary or "safety" element which remains undisturbed during primary filter change should be used. Its higher initial cost is offset by its contribution to longer engine life.

Standard Air Cleaners

The standard air cleaner on most Caterpillar engines uses a high-efficiency, dry paper element packaged in a low restriction, weather resistant housing. They remove 99.5% of AC fine dust and are designed to minimize dust entrance during filter changes. Some newer models use a PowerCore air cleaner featuring a special nanofiber element design. These cleaners achieve the filtration goals with lower restriction to air flow than the dry paper element design.

On most engine models, these air cleaners are engine mounted, however, on some engines the air cleaners are supplied loose for remote mounting. See Remote Mounted Air Cleaners later in this section. Refer to the engine price lists for availability of air cleaner options on specific engine models.

Heavy-Duty Air Cleaners

Heavy-duty air cleaners provide the same protection as standard filters but allow extension of filter change periods. Depending on the engine air-flow rate and filter type, service periods may be extended six to seven times that of standard air cleaners.

Depending on specific design, dual element air cleaners may also be categorized as heavy duty air cleaners.

Precleaners

Precleaners are an available option on some Caterpillar engines, which, when added to the standard air cleaner, can extend filter service periods.

The precleaner imparts a swirl to the air, centrifuging out a major percentage of the dirt particles which may be collected in a reservoir or exhausted out on either a continuous or an intermittent basis.

A flow restriction of 0.25 to 1.5 kPa (1 to 6 in. H₂O) is imposed by the precleaner, but it can prolong the life of the filter by three to seven times. Any application in an environment with heavy dust and debris is recommended to use a precleaner.

Dual Element Air Cleaners

Dual element air cleaners can be used to provide additional protection for the engine. This arrangement uses two elements mounted in series. The secondary filter remains in place while the primary filter is serviced.

A dual element configuration differs from a double element configuration in that the two elements are used in parallel.

Dual element air cleaners are also available with a precleaning stage.

Exhaust Ejector

In extremely dusty environments where dust and other particles cause air cleaners to plug up quickly, an improved precleaner has been designed. It is an integral part of an exhaust aspirated air cleaner system and will extend the service life of the air cleaner elements.

Using a louvered body design, the precleaner has a very high separator efficiency. It will separate and remove over 90% of the dirt and chaff from the incoming air stream.

Example of Precleaner, Air Cleaner and Exhaust Ejector

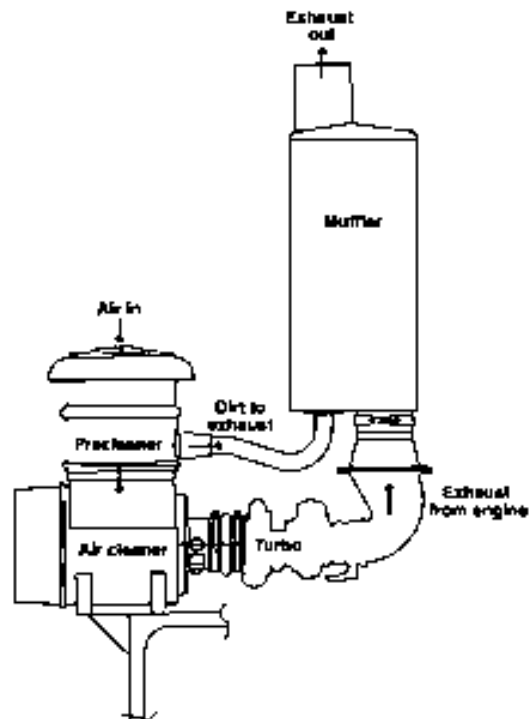

Figure 1

The air comes into the precleaner where the dirt and chaff is removed from the air. With a slight vacuum, the dirt is sucked directly through the muffler into the exhaust flow and does no harm to the engine. Refer to **Figure 1**.

The remaining dust in the air is then removed by the air cleaner before it enters the turbo.

With this system, consideration must be made regarding the location of exit of the exhaust and the surroundings, as there may be particles in the engine exhaust.

Oil-Bath Air Cleaners

Oil-bath air cleaners, while sometimes required to meet customer specifications, are not recommended by Caterpillar. At best their efficiency is 95% as compared to 99.5% for dry-type filters. Their relative ease of service and insensitivity to water are advantages easily outweighed by disadvantages, such as:

- Lower efficiency
- Low ambient temperature limits, low oil level, high restriction at low air flow (such as at low idle), and installed tilt angle may lessen efficiency further.
- Oil carry-over, which is the oil becoming airborne in the air intake system whether resulting from overfilling or increased air flow, can seriously affect turbocharger and engine life, and may actually become an engine fuel.

Remote Mounted Air Cleaners

Due to air flow requirements and size considerations, it is impractical to mount G3520C and 3600/G3600 air cleaners on the engine. They are furnished as shipped loose items, and must be remote mounted and plumbed by the customer. The air cleaner housings may be wall, floor, or roof mounted with the inlet facing downward, or they can be oriented for horizontal entry, but modifications are required to support the elements.

Two element (double) and three element (triple) air cleaner housings are available. Unlike the dual element arrangement, air flow through these elements is in parallel.

The double and triple air cleaner housings have optional precleaners and soot filters, to extend element life in severe applications. Examples of remote air cleaner housings are shown in **Figure 2** and **Figure 3**.

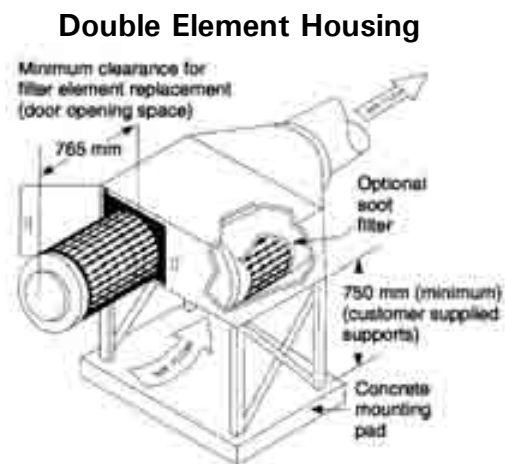

Figure 2

Double Element Housing with 3 Precleaners

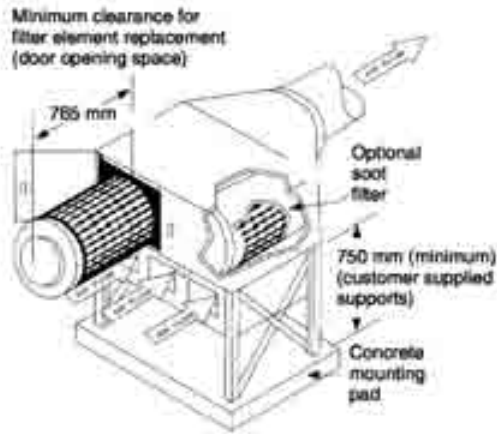

Figure 3

For marine and offshore applications, where remote mounted air cleaners may be located in a salt water environment, epoxy coated housings are available. Refer to **Figure 4** and **Figure 5** in the next section for typical marine arrangements for remote mounted air cleaners.

Dirty or improper filters can restrict intake air flow. Differential pressure readings should be used to signal needed filter changes.

Caution: Under no circumstances should the engine be operated without air cleaners.

If the air cleaner enclosure(s) are outside in the weather, a protective shield is recommended to prevent rain from being pulled into the cleaners/precleaners.

Customer Furnished Air Cleaners

Air Cleaner Efficiency

Customer furnished air cleaner selection should be based upon the following air cleaner efficiency test:

A satisfactory air cleaner must meet the International Organization of Standardization’s requirement of the ISO 5011 dust test.

The filter should have 99.5% minimum efficiency as calculated following test code with additions and exceptions as follows:

- Air flow corrected to m³/min at 99.9 kPa pressure and 32.2°C (ft³/min at 29.6 in. Hg pressure and 90°F).
- Use sonic dust feeder.
- Dust quantity determined by light-duty class.
- Filter to be dried and weighed in an oven at 93°C to 107°C (200°F to 225°F) before and after test.
- Use AC fine dust.

AC fine dust is defined as follows:

Particle Size (microns)	% Total Weight
0 – 5	39 ± 2
6 – 10	18 ± 3
11 – 20	16 ± 3
21 – 40	18 ± 3
41 – 80	9 ± 3

99.5% filtration of the AC fine dust has been determined to be a practical combination of the kind of

dirt likely encountered in service, and will result in an air cleaner efficiency expected to give optimum engine wear life.

Air Cleaner Design Requirements

Following the above procedure will establish sufficient control on the filter media filtering ability of the tested air cleaner, but there are other design variables needing further control.

- Choose filters supplied by manufacturers that can best provide quality control.
- Design filters to be resistant to damage at initial assembly or during cleaning. If end seal and filter media are subject to damage, dust leakage into the engine can result.

Air Cleaner Dust Calculation

3600/G3600 engines must not ingest more than 34.5 mg/hr/cylinder of dust at rated power to achieve acceptable engine life. Air cleaners offered by Caterpillar are designed to this requirement. Customer provided air cleaners must also meet this requirement or reduced engine life will result. Specific dust consumption for various engines, air cleaners, and environments can be calculated using the following formula.

$$D = \frac{V \times d \times (1 - e) \times 60}{n}$$

Where:

- D = Specific dust consumption in mg/hr/cylinder
- V = Intake air flow in cu ft/min (cfm).
- d = Dust concentration in mg/cu ft (Estimated dust concentration for residential and offshore applications is 0.001 to 0.002 in mg/cu ft. Estimate industrial and inland waterway applications at 0.002 to 0.05 in mg/cu ft.)
- e = Average air cleaner efficiency (always < 1.0) (estimated efficiency of paper elements = 0.99, & estimated efficiency of non-paper elements = 0.95)
- n = Number of engine cylinders (6, 8, 12 or 16)

Example A

A 3606 Engine operating at 900 rpm in an EPG application with non-paper elements.

- V = 5554 CFM
- d = 0.02 mg/cu ft
- e = 0.95
- n = 6

$$D = \frac{5554 \times 0.02 \times (1 - 0.95) \times 60}{6}$$

Example A equates to a dust consumption of 55.54 mg/hr/cylinder. Since the engine must not ingest more than 34.5 mg/hr/cylinder of dust for acceptable engine life, this air cleaner system is unacceptable.

Example B

Using the same engine but with paper air cleaner elements that offer approximately 0.99 efficiency ($e = 0.99$).

$$D = \frac{5554 \times 0.02 \times (1 - 0.99) \times 60}{6}$$

Example B equates to a dust consumption of 11.1 mg/hr/cylinder. This air cleaner system will provide acceptable engine life.

Combustion Air Flow Requirements

Combustion air flow requirements will vary, depending on the specific engine model and rating. Specific air flow data for Caterpillar engines is given in both volumetric [m^3/min (cfm)] and mass [kg/hr (lb/hr)] flow terms, at standard reference conditions.

Reference conditions for temperature and pressure are used to provide a basis for consistent measure of combustion air quantities. However, different parts of the world subscribe to different standards, thus it is important to note that the metric and English conditions are not equivalent. Caterpillar practice is to use ISO 8528 "normal" conditions of 25°C (77°F) and 101.3 kPaa (14.7 psia) when providing values in metric units, and ASME SAE J1349 "standard" conditions of 25°C (77°F) and 101.3 kPaa (14.7 psia) when providing values in English units.

To convert from mass airflow to volumetric airflow at reference conditions, use the following formula:

$$\frac{M_R}{S_R} = Q_R$$

Where:

M_R = Mass air flow at reference conditions (kg/hr), (lb/hr)

Q_R = Volumetric air flow at reference conditions (m^3/min), (cfm)

S_R = Density of air at reference conditions (kg/m^3), (lb/ft^3).
(Density of air = 1.292 kg/Nm^3 (0.074 lb/ft^3))

To convert both mass airflow and volumetric air flow from reference conditions to site conditions, use the following formulas:

$$M_R \times \frac{T_S}{T_R} = M_S$$

$$Q_R \times \frac{T_S}{T_R} = Q_S$$

Where:

M_R = Mass flow at reference conditions (kg/hr), (lb/hr).

M_S = Mass flow at site conditions (kg/hr), (lb/hr).

Q_R = Air flow at reference conditions (m^3/min), (cfm).

Q_S = Air flow at site conditions (m^3/min), (cfm).

T_R = Air temperature at reference conditions ($^{\circ}\text{K}$), ($^{\circ}\text{R}$).

T_S = Air temperature at site conditions ($^{\circ}\text{K}$), ($^{\circ}\text{R}$).

$^{\circ}\text{K} = ^{\circ}\text{C} + 273$.

$^{\circ}\text{R} = ^{\circ}\text{F} + 460$.

Air Intake Ducting

General

When ducting is necessary to obtain cooler or cleaner air, the filters should remain on the engine to prevent harmful dirt from leaking into the engine through ducting joints. When air cleaners must be remote-mounted it is extremely important that all joints be air tight to prevent ingestion of dirt.

When designing air intake ducting, consideration must be given to appropriate routing, duct support and system restriction, especially on the larger engines, where overhead cranes are used to service the engines. Proper support for duct work adjacent to the engine is critical, so that its weight is not borne by the turbocharger or other engine-mounted components.

Locate the air piping away from the vicinity of the exhaust piping so that the air provided to the engine is as cool as possible. Air temperature to the air inlet should be no more than 11°C (20°F) above ambient air temperature. Inlet air temperature should not exceed 45°C (113°F) for standard ratings.

Avoid abrupt transitions in the intake ducting to provide the smoothest possible air flow path. When unavoidable, transitions should be made as far upstream of the turbocharger as possible. Keep total duct head loss (restriction) below 0.5 kPa (2 in. H₂O) for maximum filter life. Any additional restriction will reduce filter life.

To allow for minor misalignment due to manufacturing tolerances, engine-to-enclosure relative movement and isolate vibrations, segments of the piping should consist of flexible rubber fittings. These are designed for use on diesel engine air intake systems and are commercially available. These fittings include hump hose connectors and reducers, rubber elbows and a variety of special shapes.

Wire-reinforced flexible hose should not be used. Most material available is susceptible to damage from abrasion and abuse and is very difficult to seal effectively at the clamping points unless special ends are provided on the hose.

Inlet ducting should be designed to withstand a minimum vacuum of 12.5 kPa, (50 in. H₂O), which is also the structural capability of the Caterpillar air cleaner filter element.

Piping diameter should be equal to or larger than the air cleaner inlet/outlet and the engine air inlet. A rough guide for pipe size selection is to keep maximum air velocity in the piping to 10 m/s (2,000 fpm). Higher velocities will cause high noise levels and excessive flow restrictions. Refer to the Air Intake Restriction section for guidance in determining required intake duct sizing.

All piping must be designed and supported to meet any local seismic requirements that may be in force.

The ducting should be of seamless or welded seam piping to minimize the flow restriction. The ducting should also be constructed of materials suitable for local environmental conditions such as offshore or marine applications.

Beaded pipe ends at hose joints are recommended. Sealing surfaces should be round, smooth and free of burrs or sharp edges that can cut the hose. The tubing should have sufficient strength to withstand hose clamping forces. Either T-bolt type or SAE type F hose clamps that provide a 360° seal should be used. High quality clamps must be used. Double clamps are recommended on connections downstream of the air cleaner.

PVC piping has a number of benefits. It is light-weight, provides a good seal without the chance of weld slag coming loose and will not rust. However, it is not well suited for high or low temperature environments. It can lose much of its strength when subjected to temperatures of 150C (300F) or above. It can also become brittle and shatter at low temperatures. If using PVC pipe, use at least schedule 40 pipe and check that it meets local regulations for the area classification.

If ferrous material is necessary, it must be properly cleaned after fabrication and treated to prevent rust and scale from accumulating. Stainless steel ducting should be treated in the same manner. Flanged connections with gaskets are preferred over threaded connections. Fasteners such as rivets should not be used.

Unsupported weight on clamp-type joints should not exceed 1.3 kg (3 lb).

Marine Intake Air Piping Examples

Figure 4 shows a 3600 marine application configured to use a remote mounted air cleaner and outside air for combustion. An intake air heater may be required for cold weather operation.

Figure 5 shows a 3600 marine application configured to use a remote mounted air cleaner and engine room air for combustion.

C175 Remote Mount Air Cleaner

Figure 5A shows a C175 application to use a remote mounted air cleaner and outside air for combustion. An intake air heater may be required for cold weather operation.

Remote Mounted Air Cleaner with Outside Air Intake

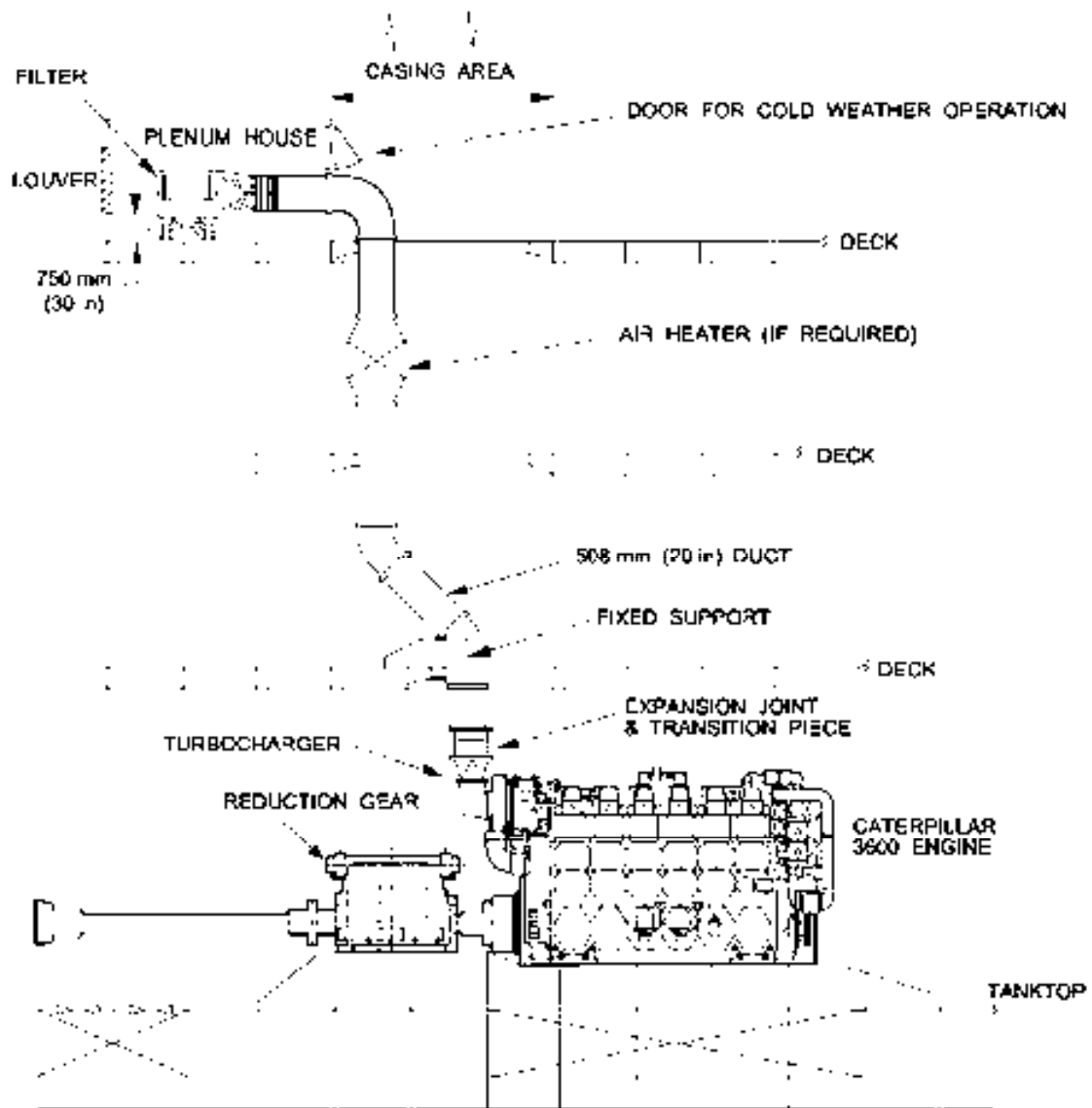

Figure 4

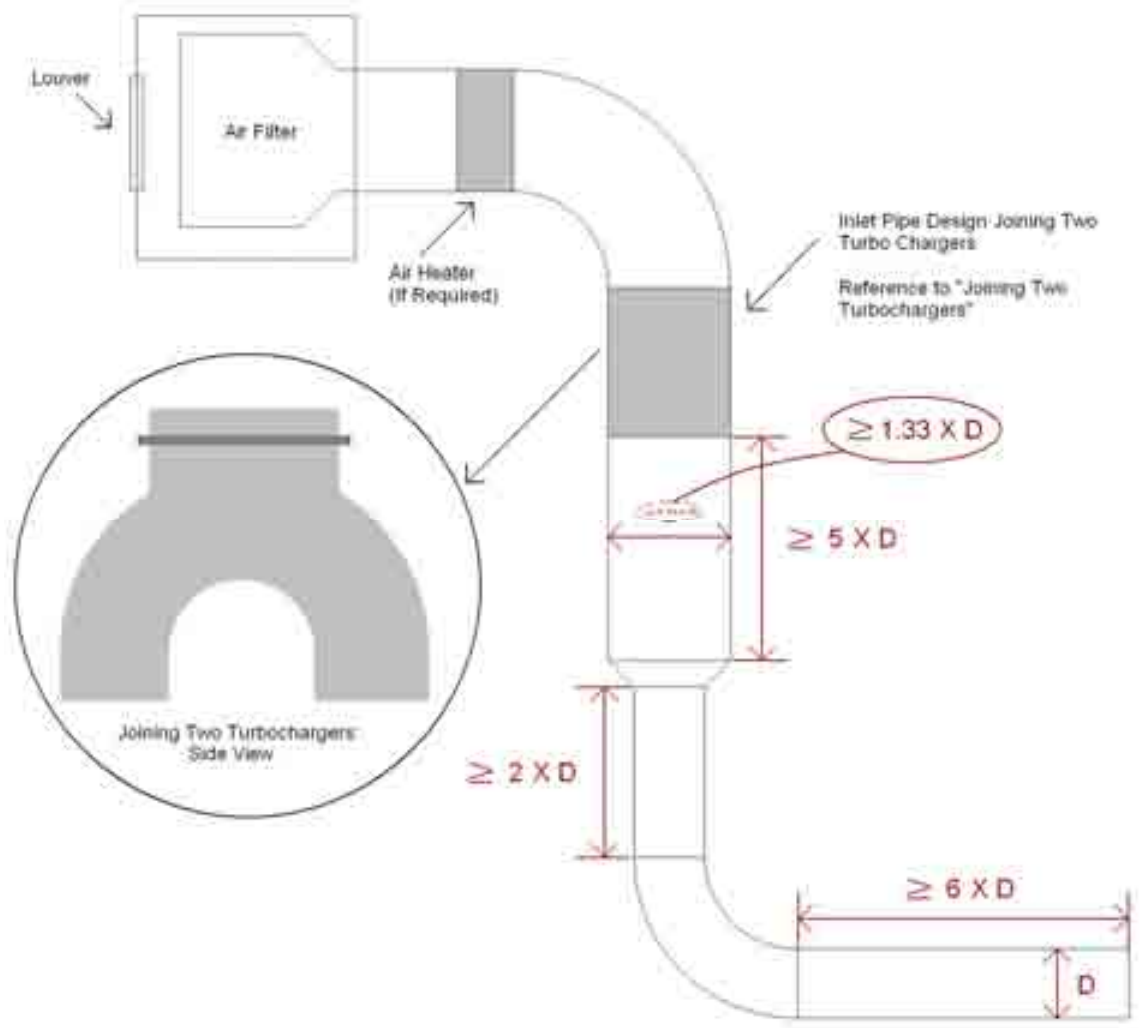

Figure 4A

Remote Mounted Air Cleaner with Engine Room Air Intake

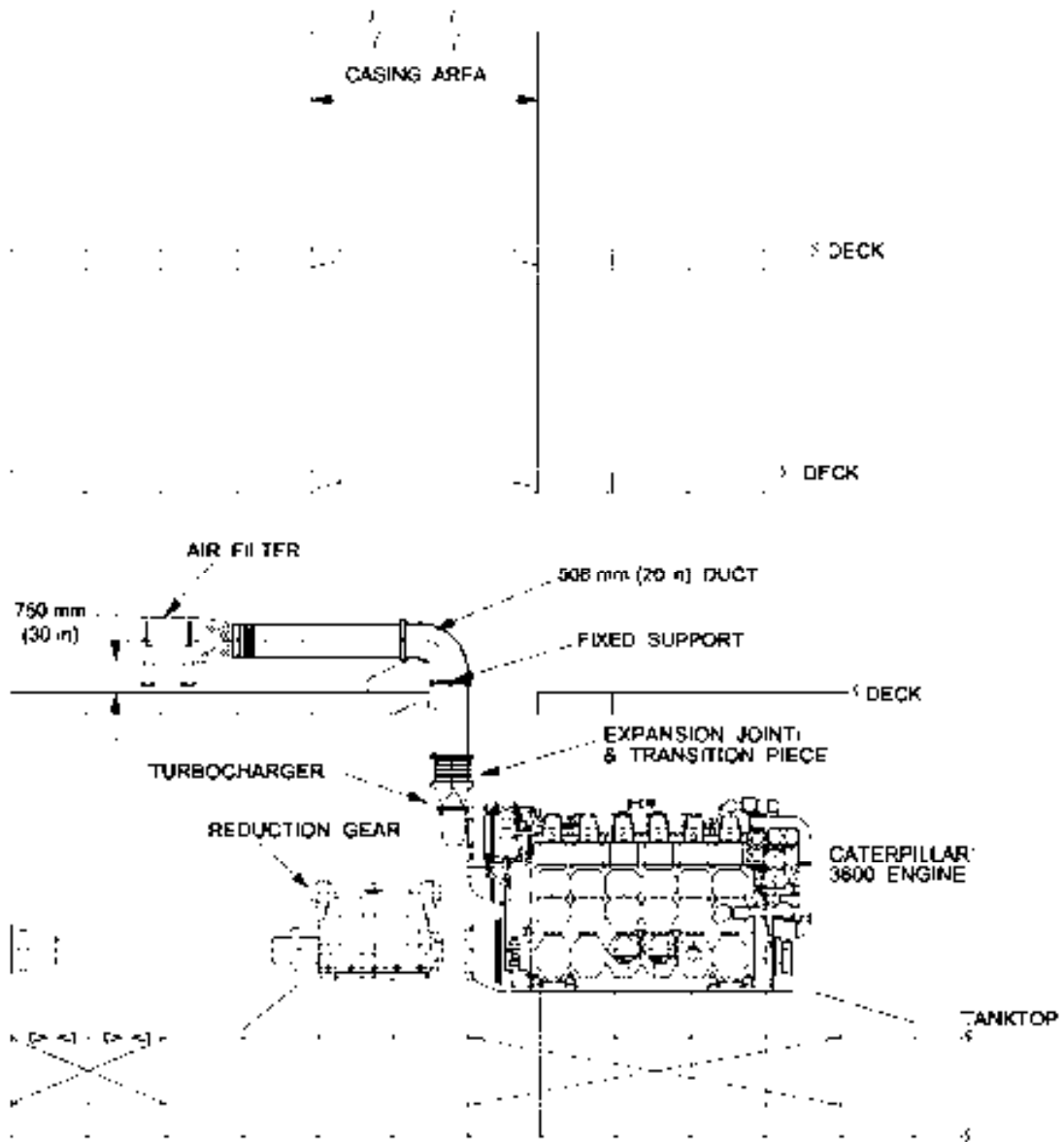
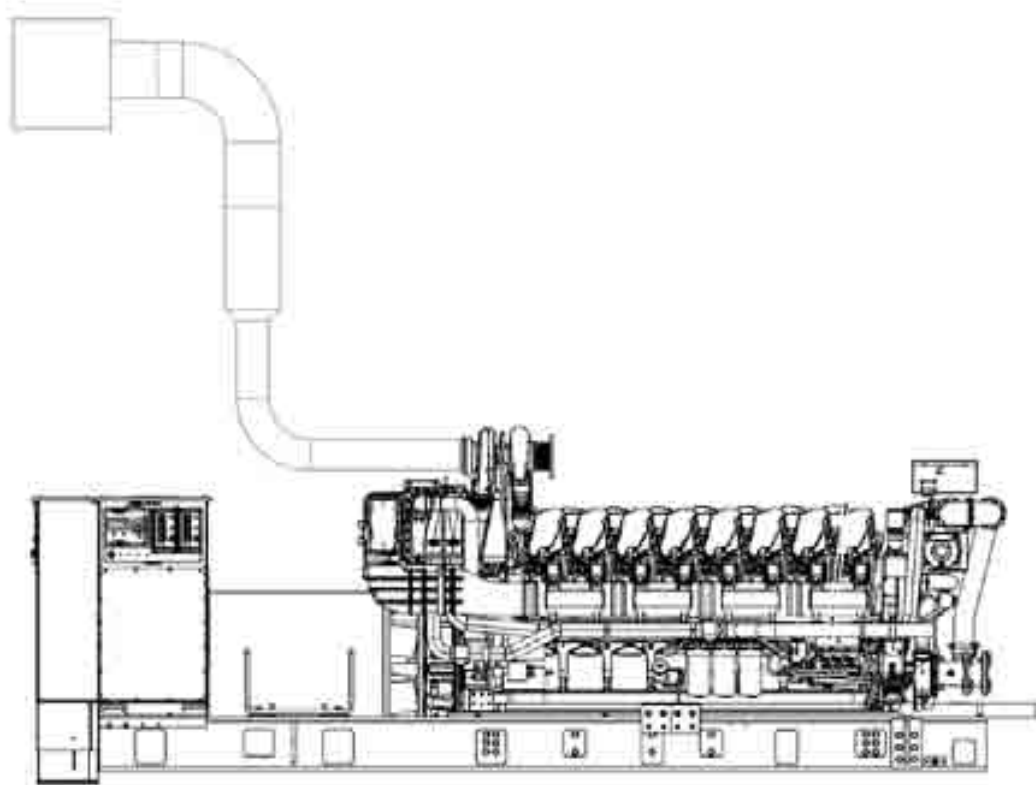

Figure 5

**Figure 5A**

Air Inlet Adapters

Caterpillar offers various air inlet adapters for connecting to turbocharger air inlets. The adapters are part of the system to provide an efficient transition from the engine room intake air ducting to the engine turbocharger. Adapters are typically shipped loose and include gaskets and mounting hardware.

CAUTION: Turbocharger performance may be adversely affected if appropriate air intake components are not used (they are designed to provide the proper air flow pattern ahead of the turbocharger).

Connections to Inlet Adapters and Turbochargers

The piping connected to the turbocharger inlet should be designed to ensure that air is flowing in a straight, uniform direction into the turbocharger compressor. This is typically achieved by installing a straight section of pipe, equal in length to at least two or three times pipe diameter, to the inlet. This arrangement reduces the possibility of premature compressor wheel failure due to pulsations created by air striking the compressor wheel at an angle. Transitional ducting immediately preceding the straight

section of pipe should consider the following guidelines:

- The duct between the straight pipe and elbow cannot have protruding edges.
- The bend can be designed as a circular arc or with sections of mitered pipe with rectangular or round flow cross sections, or as

transition from round to rectangular cross section.

- An accelerated flow is expected to occur in the bend. The flow area (F) should be: $F_1 > 1.5 \times F_2$, as shown in **Figure 6**.

Turbocharger Vertical Inlet Design Options

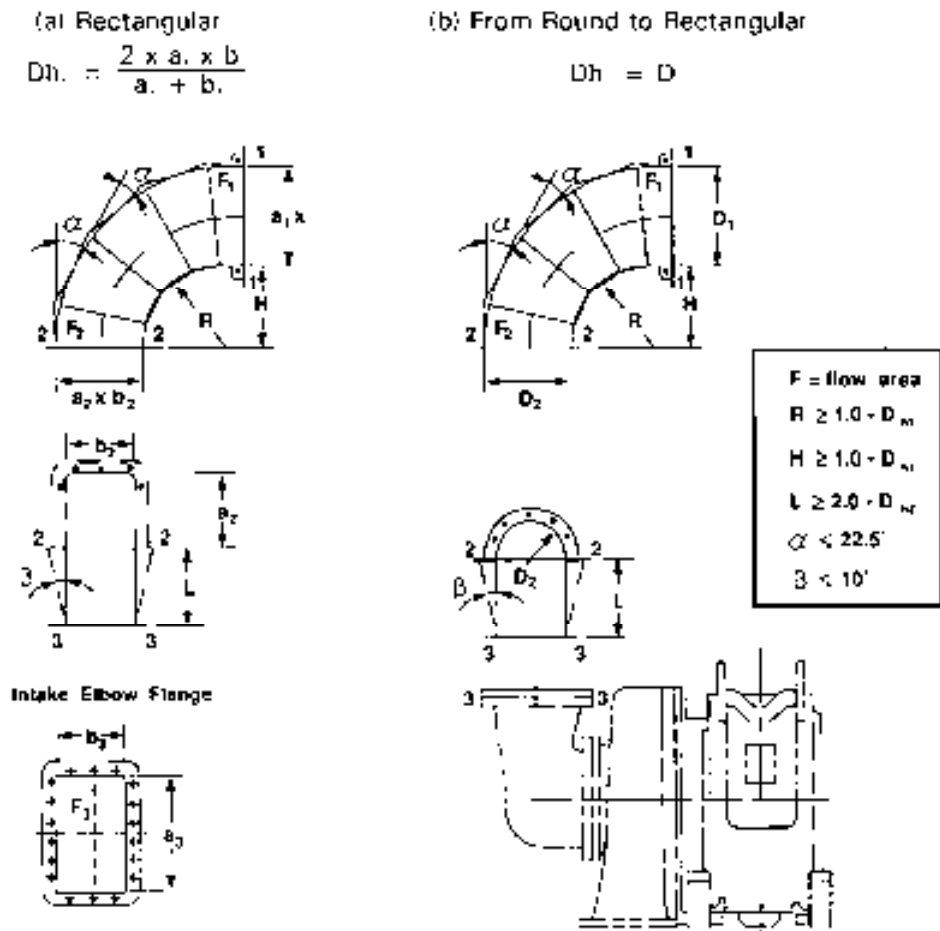

Figure 6

Inlet Pipe Design Joining Two Turbochargers

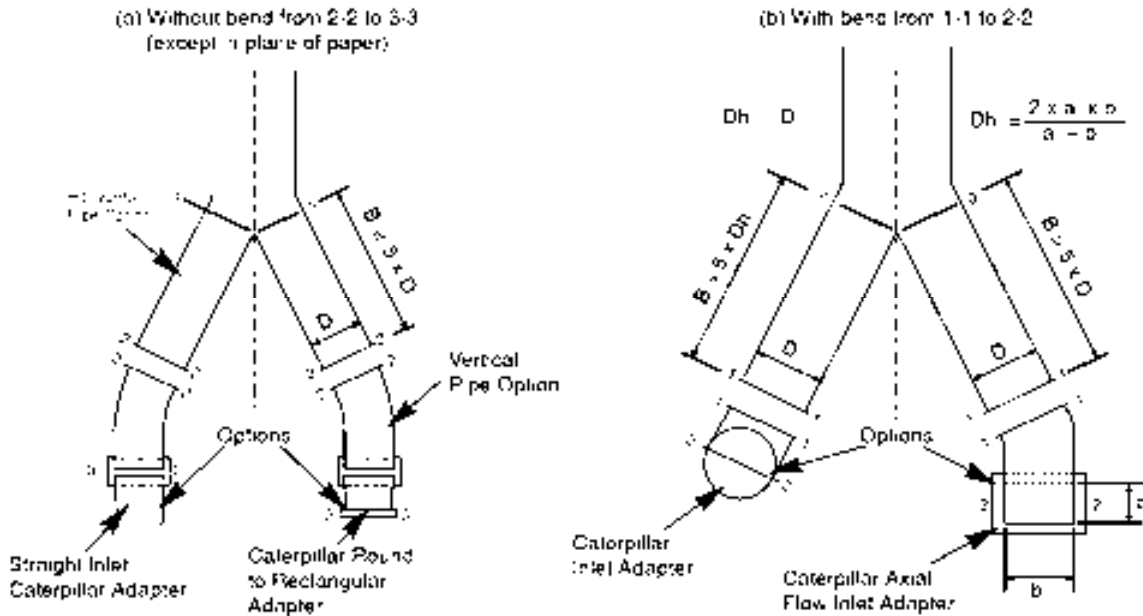

Figure 7

Joining Two Turbochargers

When ductwork feeding two turbochargers is combined to form a single duct, a steadying zone must be provided after the dividing joint; as shown in **Figure 7**. The steadying zone B must be a minimum of 5 times the pipe diameter:

$$B > 5 \times Dh_1$$

The flow area is:

$$F_0 = 1.0 \div 2.0 \times F_1$$

The transitions from Sections 0-0 to 1-1 and from 1-1 to 2-2 will have many circular or rectangular variations due to turbocharger hardware and installation site design. Regardless of the transition

selected, the steadying zone must be provided.

The transitions used to combine multiple ducts must also follow typical design standards described in this guide. Ducts should have smooth transitions and not cause disturbance in the air flow. Piping designs that use a Tee, as shown in **Figure 8**, should not be used to connect multiple ducts.

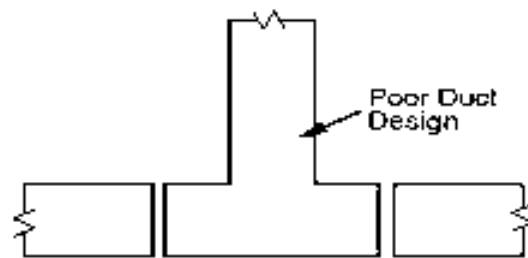

Figure 8

Turbocharger Loading

When remote-mounted air cleaners are used, turbocharger loading from the weight of the air inlet components becomes a concern. The turbochargers are not designed to support any additional weight beyond standard factory attachments. When possible, make the flexible connection directly to the turbocharger air inlet, as shown in **Figure 9**. All duct work to that point must be supported off-engine.

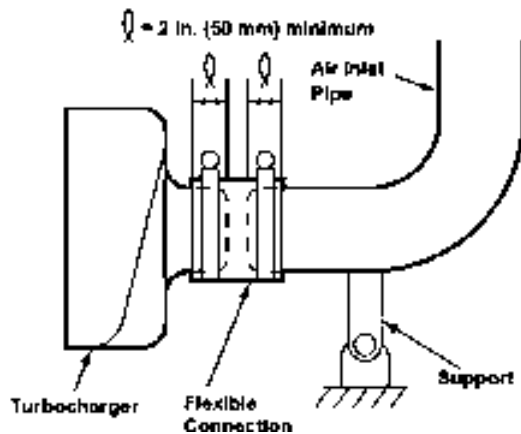

Figure 9

The maximum allowable turbocharger load will vary, depending on the engine model, the inlet adapter and the adapter orientation. In the example below, **Figure 10**, the 90° inlet adapter can be rotated in 30° increments. Turbochargers for 3600/G3600 engines are designed to withstand a maximum moment of 294 N•m (217 ft-lb). **Figure 10** shows how the moment can be calculated.

Models that provide a mounting bracket for the turbocharger inlet adapter, such as the C15, can support up to 11.3 kg (25 lb) of duct weight.

Maximum Loads for Turbocharger Intake

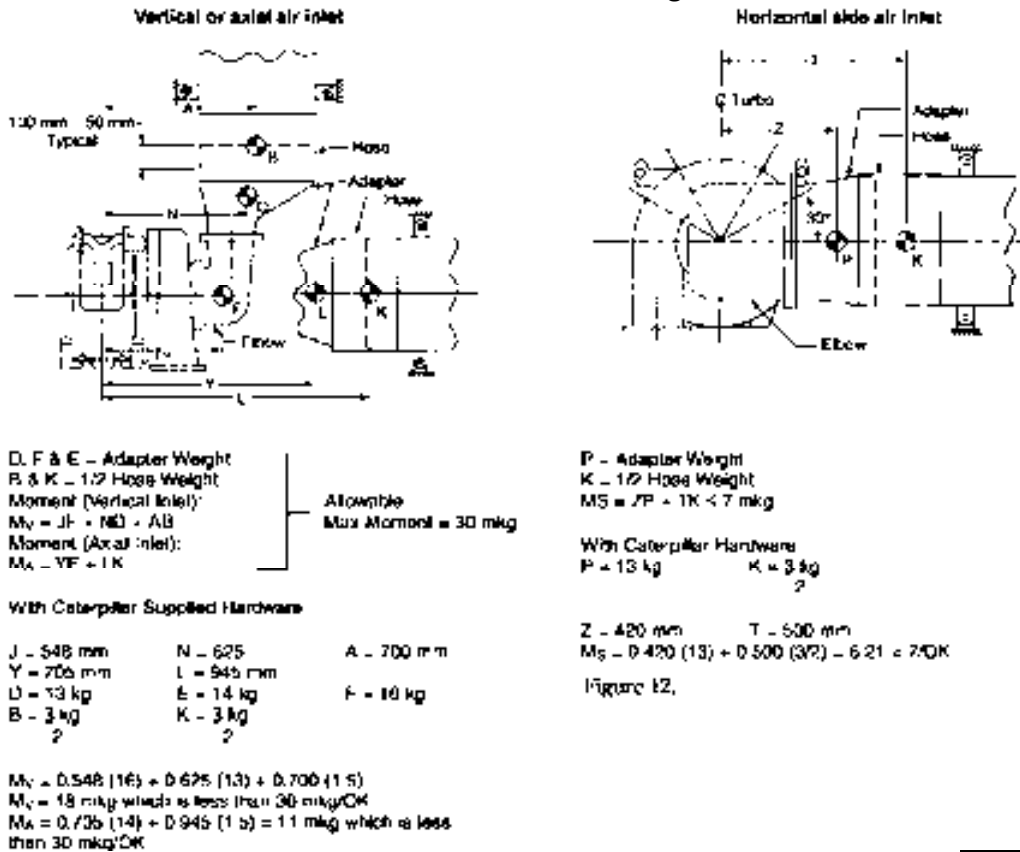

Figure 10

Flex Connections

Flexible connections are required to isolate engine vibration and noise from the ducting system. The connections should be configured for maximum allowable offset and compression to prevent early failure and excess forces on the turbocharger and air inlet components. The flexible connection should be as close to the engine as practical and installed in such a way to not induce stress on the ducting system. The flex engagement with the air intake duct should be a minimum of 50 mm (2 in.) and a maximum of 200 mm (8 in.). Care must be used to prevent exhaust piping heat from deteriorating rubber flex connections.

Cleanliness During Installation

The air intake ducting must be cleaned of all debris. Fabricated ducting, utilizing fasteners such as rivets, should not be used. The ducting should be made of material such that prolonged operation will not result in debris coming loose and entering the turbocharger.

An identifiable blanking plate should be installed ahead of the turbocharger to prevent debris from entering during initial installation of the unit. The plate should have a warning tag indicating it has to be removed prior to starting the engine. The Caterpillar supplied shipping cover can be used for this purpose.

Provisions should be made to inspect the ducting for cleanliness just prior to initial start up. If the piping is not clean, it must be cleaned before the engine is started at commissioning. This may require removal of the piping from its installed position.

Inlet Air Duct Insulation

Insulation may be needed on the intake ducting for remote mounted air cleaners. Insulation reduces turbocharger noise emitted into the engine room and will minimize pre-heating of intake air.

Air Intake Restriction

Excessive vacuum on the inlet side of the turbocharger (or the air inlet on naturally aspirated engines) can result in reduced engine power capability and degrade engine performance.

Air intake restriction is also an emissions critical parameter declared to obtain EPA non-road certification. Therefore, the air intake system's total restriction (including dirty filters, duct work, vents, silencers, etc.) is limited depending on engine model, rating and air configuration. The air intake restriction limits for Caterpillar engines can be found in the Technical Information Appendix or TMI.

In order to maximize air filter life, it is important to keep total duct restriction below 0.5 kPa (2 in. H₂O). Every additional restriction caused by the air inlet system subtracts from air filter life. Maximum filter life is partially dependent on the absolute pressure differential between the

turbocharger compressor inlet and atmosphere.

Inlet air restriction includes the pressure losses between the air cleaner and the engine air inlet connection. For remote mounted air cleaners, the following formulas can be used to calculate duct restriction.

$$P(\text{kPa}) = \frac{L \times S \times Q^2 \times 3.6 \times 10^6}{D^5}$$

$$P(\text{in. H}_2\text{O}) = \frac{L \times S \times Q^2}{187 \times D^5}$$

Where:

P = Restriction (kPa), (in. H₂O)

psi = 0.0361 x in. water column

kPa = 6.3246 x mm water column

L = Total equivalent length of pipe, measured in (m), (ft)

Q = Inlet air flow, measured in (m³/min), (cfm). - (found in TMI or performance book, and corrected for site conditions when necessary)

D = Inside diameter of pipe, measured in (mm), (inches)

If the duct is rectangular, as shown in **Figure 11**:

Then:

$$D = \frac{2 \times a \times b}{a + b}$$

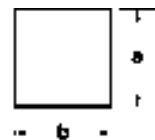

Figure 11

$S =$ Density of air kg/m^3 (lb/ft^3)

$$S(\text{kg/m}^3) = \frac{352.5}{\text{Air Temperature} + 273^\circ\text{C}}$$

$$S(\text{lb/ft}^3) = \frac{39.6}{\text{Air Temperature} + 460^\circ\text{F}}$$

Use the following formulas to obtain equivalent lengths of straight pipe for various elbows.

Standard Elbow
(radius = diameter) $L = \frac{33D}{X}$

Long Radius Elbow
(radius = 1.5 diameter) $L = \frac{20D}{X}$

45° Elbow
(radius = 1.5 diameter) $L = \frac{15D}{X}$

Square Elbow
(radius = 1.5 diameter) $L = \frac{66D}{X}$

Where:

$$x = 1000 \text{ mm (12 in.)}$$

As shown above, if 90° bends are required, long radius elbows, with a radius of 1.5 times the pipe diameter, offer lower resistance than standard elbows.

Example

Below is an example of an air intake duct restriction calculation.

A 3412 packaged genset has an inlet air flow of $36.7 \text{ m}^3/\text{min}$ (1292 cfm) with duct configuration consisting of 3 m (10 ft) of straight length duct along with 2 standard elbows and a long radius elbow. The pipe has a diameter of 152.4 mm

(6 in) and the temperature of the air is 55°C (131°F).

First calculate the total equivalent length of the ducting.

$$L = \frac{3000 \text{ mm} + 2(33 \times 152.4)}{1000 \text{ mm}} + \frac{20 \times 152.4}{1000 \text{ mm}}$$

$$L = 16.1 \text{ m}$$

$$L = \frac{120 \text{ in} + 2(33 \times 6)}{12 \text{ in}} + \frac{20 \times 6}{12 \text{ in}}$$

$$L = 53 \text{ ft}$$

Next, calculate the density of the air.

$$S = \frac{352.5}{55 + 273^\circ\text{C}}$$

$$S = 1.075 \text{ kg/m}^3$$

$$S = \frac{39.6}{131 + 460^\circ\text{F}}$$

$$S = 0.067 \text{ lb/ft}^3$$

Lastly, insert the previous results into the duct restriction formula and calculate.

$$P = \frac{16.1 \times 1.075 \times 36.7^2 \times 3.6 \times 10^6}{152^5}$$

$$P = 1.02 \text{ kPa or } 104 \text{ mm H}_2\text{O}$$

$$P = \frac{53 \times 0.067 \times 1292^2}{1.87 \times 6^5}$$

$$P = 0.147 \text{ psi or } 4.07 \text{ in H}_2\text{O}$$

Total duct restriction should be below 0.5 kPa (2 in. H₂O). The duct restriction in this example is above the desired value, and therefore this duct configuration is unacceptable.

Additional Considerations

Service Indicators

Vacuum sensing devices designed to indicate the need for air cleaner servicing are commercially available and when added to the air intake system, serve a vital function. There are two types of sensing devices, both recommended for use.

Service indicators are installed directly into the intake air ducting and sense the pressure differential between the air in the intake ducting and the air outside the ducting.

It must be noted that in installations using outside air for combustion, engine room pressure and outside, or atmospheric, pressure is not always the same. The indicator must be installed so that it senses the air in the intake duct on one side and the air from where it was drawn on the other.

Trip Lock Device

The trip lock device indicates that the air cleaner condition is either satisfactory or in need of service. When in need of service, it typically will have a red display. This type of mechanism uses a spring-loaded diaphragm to measure the pressure differential between the clean and dirty side of the air cleaner. The trip or latching type is preferred and available on most engine price lists.

Differential Pressure Gauge

The direct reading differential gauge indicates the actual pressure differential across the intake air filter. One end of the gauge is connected to the air inlet duct and

the other end to a straight length of pipe immediately upstream of the turbocharger.

Intake Air Silencers

A Caterpillar air intake filter/silencer is available for use with 3600 diesel engines. It cannot be used with G3600 gas engines due to turbocharger orientation.

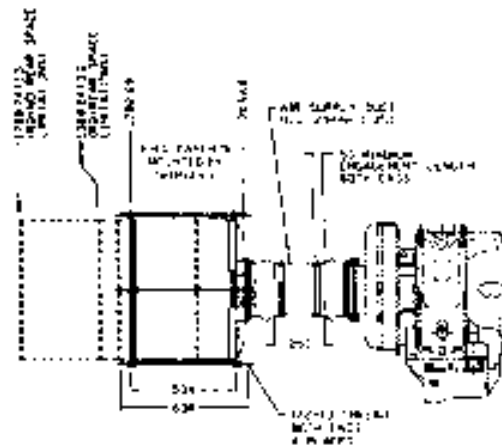

Figure 12

The filter/silencer provides good air filtration, but it should only be used in a clean engine room environment (filtered air). The customer is responsible for ensuring the engine room air is suitably filtered.

Unless specifically designed for such a purpose, intake air silencers should be remote mounted from the turbocharger inlet as shown in **Figure 12**.

Air Inlet Shut Off

Air inlet shut-off is a feature specific to the diesel engine air intake system. It provides a positive means of stopping the combustion

process in the event of an emergency shutdown by stopping the flow of combustion air. This is not recommended for gas engines, as they have the ability to positively stop the combustion process by controlling the source of ignition.

The air inlet shut-off feature is standard on 3600 diesel engines and available on many other Caterpillar diesel engines. It is normally used when an engine will be operating in a potentially combustible environment. This feature can be actuated manually or electronically, but is for emergency use in case of engine overspeed only, not for normal engine shutdown.

Air Manifold Drain Valve

An air manifold drain valve is available for the 3600 diesel engine family, consisting of an automatic float valve that drains the condensate from the engine air manifold. The C175 offers a manual ball type air manifold drain valve as an option. Otherwise, draining must be facilitated by removing the standard plugs from the aftercooler outlet lines. This feature is recommended for use in applications where high humidity is expected and the possibility exists for the air inlet manifold temperature to drop below the atmospheric dew point. Refer to Caterpillar Service Publication SEBD9317 and SEBU8100 for more information on this subject.

Shielding

The air inlet should be shielded against direct entrance of rain or snow. The most common practice is

to provide a cap or inlet hood which incorporates a coarse screen to keep out large objects. This cap should be designed to keep air flow restriction to a minimum. Some users have designed a front air intake which provides a direct air inlet and an internal means of achieving water separation.

Precleaners and prescreeners incorporated into the intake cap design are also available. They can be used where special conditions prevail or to increase the air cleaner service life. These devices can remove 70% to 80% of airborne dirt.

Breakaway Joints

A breakaway joint may be used on a cab or hood to tilt away from the engine compartment for accessibility and servicing of the engine. Half of the rubber seal flange remains on the engine air intake and the other half is secured to the enclosure or hood.

If carefully designed and used only upstream of the air cleaner, breakaway joints may be used.

Note: Never use breakaway joints between the air cleaner and engine.

When breakaway joints are required, choose a joint designed for lifetime sealing under the most severe conditions and needing limited or no maintenance.

Cold Conditions

Air Cleaner Icing

Air cleaner icing can occur in saturated air environments when the dew point of the ambient air is near

freezing. Small disturbances to the air such as velocity and pressure changes at the air cleaner inlet reduce the moisture-holding capacity of the air. This results in moisture condensation and ice crystal formation. The ice buildup reduces the airflow area and increases the pressure differential across the air cleaner. Eventually, a plateau is reached where the pressure differential remains constant even though ice buildup may continue. Power loss and increased fuel consumption will result during these periods.

Several techniques may be used to overcome air cleaner icing. One solution is to heat the intake air slightly. It is not necessary to heat the air above freezing. The air requires only enough heat to be above the dew point. Heat can be supplied to the air cleaner housing by ducting engine room air. Heated air from the exhaust piping or muffler, or electrical heating tape may also be used.

Boost Control

A boost control valve is available for the 3600 diesel engine family for use in extremely cold ambient conditions, 0°C (32°F). The valve is used to limit the air inlet manifold pressure during low air temperature conditions to maintain acceptable cylinder pressure.

Extreme Cold

Heated engine room air may be required (for starting purposes only) in applications at very cold ambient temperatures, -25°C (-13°F). This assumes combustion air is being

drawn from outside the engine building, and the engine is preconditioned with pre-heaters for metal, water and oil temperatures of 0°C (32°F). Admitting engine room air must be done without the possibility of allowing dirt or debris into the air inlet system of the engine.

Considerations for Low Pressure Gas

Take special care when designing the air intake system for low-pressure gas engines that do not have air-fuel ratio control.

Carburetors used in Caterpillar gas engines meter fuel into incoming air on a volume-for-volume basis. If the density of either the air or the gas changes relative to the other, the air-fuel ratio of the engine will change, affecting emission levels and the detonation margin.

For example, if a G3516 Low Emissions engine with an 11:1 compression ratio and 32°C (90°F) A/C is adjusted to produce 2 g NO_x at full load, the percent of O₂ in the exhaust must be set to 8%, which results in an air-fuel ratio of 14.75 on a volume-for-volume basis.

If the engine is adjusted when the incoming air is 10°C (50°F) and the incoming gas is 21°C (70°F), then:

$$\begin{aligned}\Delta T1 &= 10^{\circ}\text{C} - 21^{\circ}\text{C} = -11^{\circ}\text{C} \\ (\Delta T1 &= 50^{\circ}\text{F} - 70^{\circ}\text{F} = -20^{\circ}\text{F})\end{aligned}$$

If the air temperature is later increased to 32°C (90°F) and the gas temperature remained constant, then:

$$\begin{aligned}\Delta T2 &= 32^{\circ}\text{C} - 21^{\circ}\text{C} = 11^{\circ}\text{C} \\ (\Delta T2 &= 90^{\circ}\text{F} - 70^{\circ}\text{F} = 20^{\circ}\text{F})\end{aligned}$$

The Variation in Air Temperature (VAT) would then become:

$$\begin{aligned} \Delta T &= |-11^{\circ}\text{C} - 11^{\circ}\text{C}| = 22^{\circ}\text{C} \\ (\Delta T &= |-20^{\circ}\text{F} - 20^{\circ}\text{F}| = 40^{\circ}\text{F}) \end{aligned}$$

The density of the air would then decrease, resulting in a lower air-fuel ratio of 13.67. The lower air-fuel ratio would result in reducing the percent O₂ in the exhaust to 6.5%. The graph in **Figure 13** shows how NO_x changes as a function of percent O₂ in the exhaust. The increased air temperature in our example would increase the NO_x emissions to 8.8 g NO_x /bhp-hr, which is an increase of 440%.

To maintain a 2.0 g NO_x /bhp-hr level, VAT must not exceed 5.5°C (10°F).

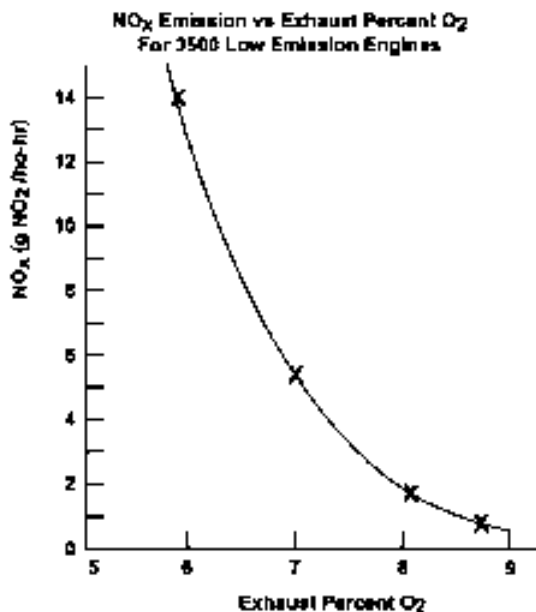

Figure 13

High pressure gas engines are not affected by these changes to the

same extent as low pressure gas engines. This is because the supply gas temperature remains relatively constant at most installations and the thermostatically controlled aftercooler maintains a fairly constant air temperature to the carburetor. Since these two temperatures are not subject to large changes, the air-fuel ratio remains relatively constant.

There are two primary methods of controlling VAT, controlling the air temperature and using a gas-to-air heat exchanger.

Controlling Air Temperature

One method of controlling air supply temperature is to regulate the engine room temperature. However, this approach is not recommended. It is difficult to regulate an engine room to a temperature that is both comfortable to work in and high enough to provide a constant air temperature to the engine. For example, an installation expecting a 32°C (90°F) ambient temperature, will need to regulate the engine room to about 38°C (100°F) at all times. Also, engine rooms having large service doors that, at times, must be left open while the engines are running, will not maintain the air-fuel ratio while the doors are open.

The preferred method is to use duct work to supply a temperature regulated air supply to the engine. See **Figure 14**. This system uses jacket water to heat the air to the temperature set by the thermostat.

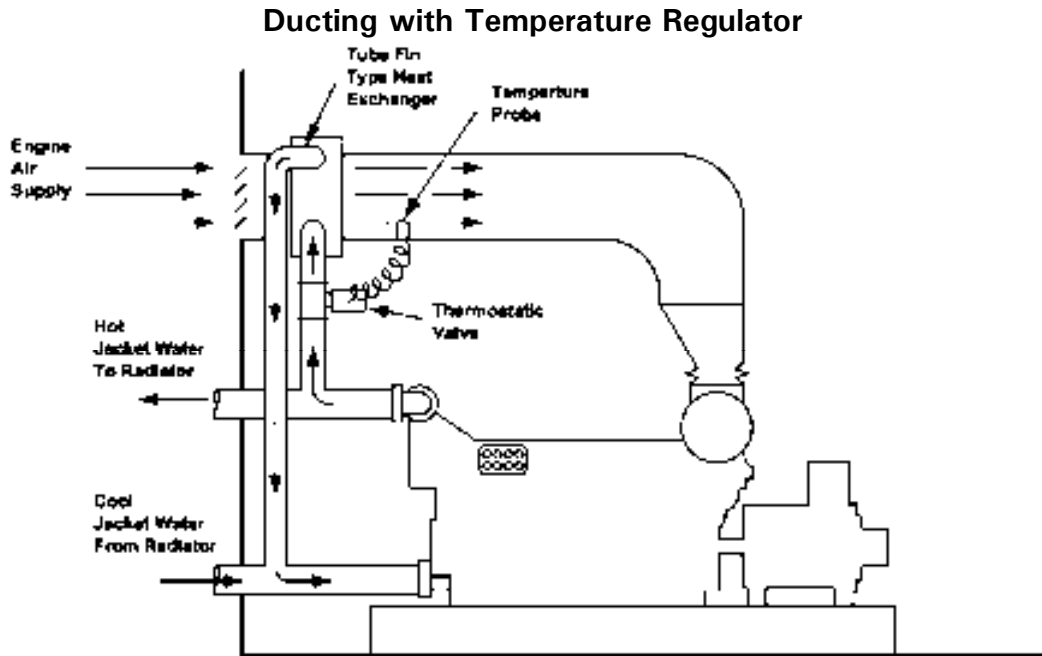

Figure 14

If one intake system is used to supply temperature controlled air to multiple engines, provisions must be made to ensure that heated water is sent to the heat exchanger when engines are running. If engine jacket water is used, the engine that the water is taken from must be running when any of the other engines are operating.

Gas-to-Air Heat Exchanger

If the use of duct work is not practical for a given installation, another option is to install a gas-to-air heat exchanger, shown in **Figure 15**. If done correctly, this system will prevent temperature changes in the gas or the air from affecting the air-fuel ratio.

Design the system so the gas flows through the heat exchanger

before entering the gas regulator. The pressure drop across the heat exchanger at full load must be added to the minimum gas supply pressure required by the engine. Design the heat exchanger to minimize both gas and air flow pressure drop while still providing enough heat transfer so that VAT stays within the given limits.

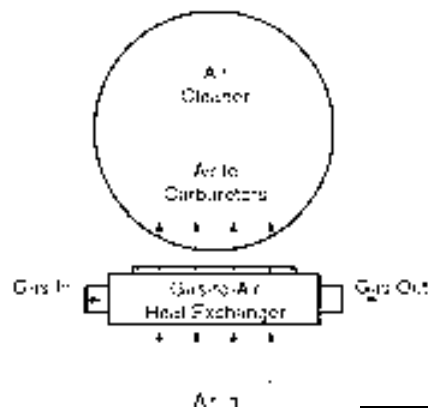

Figure 15

Reference Material

The following information is provided as an additional reference to subjects discussed in this guide.

SEBD9317

Engine News 2003/01/01.

SEBU8100

C175 Series Generator Sets

