

# ALIGNMENT



# Contents

<b>Alignment .....</b>	<b>1</b>
General Alignment Considerations.....	2
Types of Misalignment.....	2
Parallel/Bore Misalignment.....	2
Angular/Face Misalignment .....	2
Inaccurate Flanges .....	3
Alignment Tools.....	3
Laser Alignment Tools .....	3
Dial Indicators.....	3
Accuracy of Dial Indicator Readings .....	4
Support Brackets .....	4
Principles of Alignment .....	6
Cold Alignment .....	6
Hot Alignment .....	6
Crankshaft Position .....	6
Flywheel Sag or Droop.....	6
Crankshaft Endplay .....	7
Crankshaft Deflection .....	7
Torque Reaction.....	8
Thermal Growth.....	8

Alignment Related Mounting Considerations .....	10
Shimming .....	10
Metal Shims .....	10
Poured Resin Chocks .....	11
Vibracon Adjustable Chocks .....	11
Mounting Bolts .....	12
Mounting Bolt Torque .....	12
Procedure for Tightening Engine and Driven Equipment Mounting Bolts .....	13
Flexible Couplings .....	14
General Requirements .....	14
Caterpillar Couplings.....	15
Couplings By Other Manufacturers .....	15
Specific Alignment Considerations .....	16
Alignment of Close-Coupled Driven Equipment .....	16
Alignment of Remote Mounted Gear Driven Equipment ....	17
Reference Material .....	20

## Foreword

This section of the Application and Installation Guide generally describes wide-ranging requirements and options for the Alignment of Caterpillar® engines listed on the cover of this section. Additional engine systems, components and dynamics are addressed in other sections of this Application and Installation Guide.

Engine-specific information and data is available from a variety of sources. Refer to the Introduction section of this guide for additional references.

Systems and components described in this guide may not be available or applicable for every engine.

Information contained in this publication may be considered confidential. Discretion is recommended when distributing. Materials and specifications are subject to change without notice.

CAT, CATERPILLAR, their respective logos, "Caterpillar Yellow" and the POWER EDGE trade dress, as well as corporate and product identity used herein, are trademarks of Caterpillar and may not be used without permission.



## Alignment

In order to obtain optimum service life from a Caterpillar engine and its driven equipment, correct alignment between the units is required. Improper alignment results in excessive vibration, short life of driven equipment/compound bearing and coupling clutch parts, and frequent re-alignment.

Good alignment practices include proper shimming, correct torque on hold-down bolts, accurate laser or dial indicator usage, allowances for bearing clearances, thermal growth, and accounting for other characteristics of the engine. Special instructions, listed under Reference Material at the end of this section, are available with specific alignment procedures for all Caterpillar engine and driven equipment combinations.

Caterpillar marine propulsion engine alignment is covered in a separate section of the Application and Installation Guide.

### SECTION CONTENTS

<b>General Alignment</b>		<b>Flexible Couplings</b> .....	<b>14</b>
<b>Considerations</b> .....	<b>2</b>	• General Requirements	
• Types of Misalignment		• Caterpillar Couplings	
• Inaccurate Flanges		• Couplings By Other	
• Alignment Tools		Manufacturers	
<b>Principles of Alignment</b> .....	<b>6</b>	<b>Specific Alignment</b>	
• Cold Alignment		<b>Considerations</b> .....	<b>16</b>
• Hot Alignment		• Alignment of Close-Coupled	
• Crankshaft Position		Driven Equipment	
• Flywheel Sag or Droop		• Alignment of Remote	
• Crankshaft End Play		Mounted Gear Driven	
• Crankshaft Deflection		Equipment	
• Torque Reaction		<b>Reference Material</b> .....	<b>20</b>
• Thermal Growth			
<b>Alignment Related Mounting</b>			
<b>Considerations</b> .....	<b>11</b>		
• Shimming			
• Mounting Bolts			

---

## General Alignment Considerations

### Types of Misalignment

#### Parallel/Bore Misalignment

Parallel or bore misalignment occurs when centerlines of driven equipment and engine are parallel but not in the same plane. Refer to **Figure 1**.

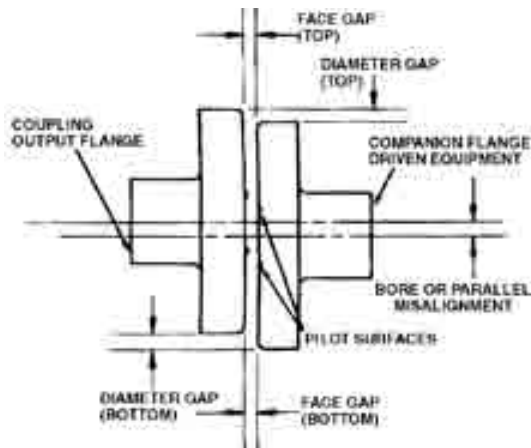
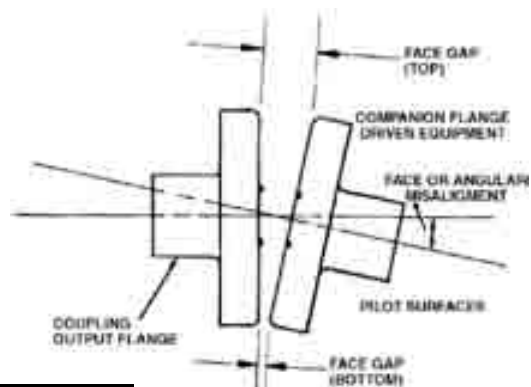

**Figure 1**

#### Angular/Face Misalignment

Angular or face misalignment occurs when centerlines of driven equipment and engines are not parallel. Refer to **Figure 2**.

#### Angular/Face Misalignment



**Figure 2**

**Figure 3** illustrates that misalignment can occur in more than one plane. For this reason, alignment readings must be taken at 90-degree intervals as the units are rotated.

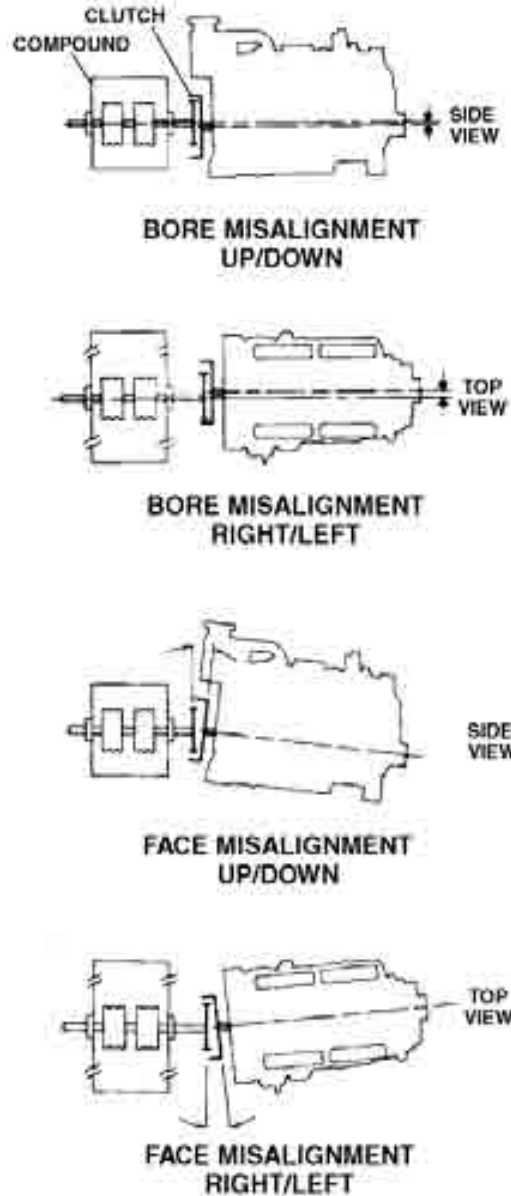
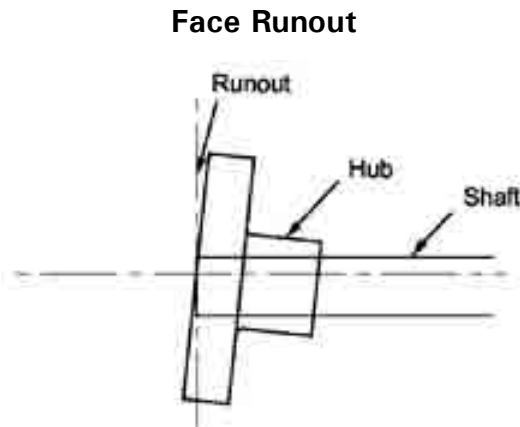

**Figure 3**

## Inaccurate Flanges

Inaccurate flanges cause apparent misalignment and make accurate alignment impossible.

Face runout refers to the distance the hub face is out of perpendicular to the shaft centerline. Refer to **Figure 4**.



**Figure 4**

Bore runout refers to the distance the driving bore of a hub is out of parallel with the shaft centerline. Refer to **Figure 5**.

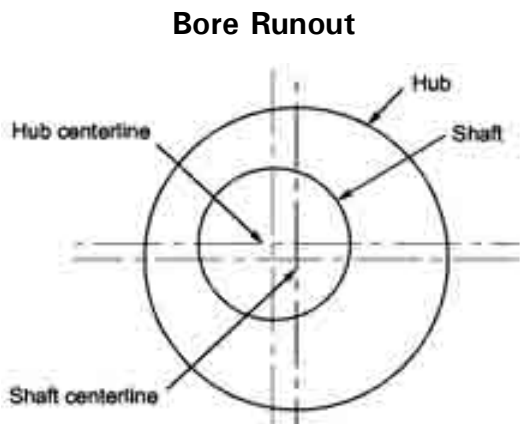

**Figure 5**

The face and bore runouts of flywheel, clutch or coupling, driven members, and hubs must be checked when inconsistent alignment results occur. Face or bore errors must be corrected. Bore-to-pilot diameter runout error should not be more than 0.05 mm (0.002 in) on the flywheel and 0.13 mm (0.005 in) on adapters bolted to the flywheel. Flange face runout should not be more than 0.05 mm (0.002 in).

## Alignment Tools

### Laser Alignment Tools

Note: The laser alignment tools typically measure the actual offsets. The dial indicators measure a total indicator reading (TIR).

Follow all the instructions that are provided by the manufacturer in order to ensure that the parallel misalignment and the angular misalignment are within the specifications.

Typically, the laser alignment tools compensate for any axial movement of the rotor shaft for the generator or the crankshaft. If the axial shaft moves during the angular measurements, consult the literature on the laser alignment tool for information.

### Dial Indicators

A dial indicator measures very small changes in distance. Alignment of shafting requires measurement of small changes in distance dimensions. The indicator must be rigidly located so the specified alignment values can be measured.

### Accuracy of Dial Indicator Readings

There is a quick way to check the validity of dial indicator face alignment readings. As **Figure 6** shows, readings are taken at four locations designated as A, B, C and D. When taking readings, the dial indicator should be returned to location A to be sure the indicator reading returns to zero. Values shown in **Figure 6** are for a unit not in alignment.

The quick check is to remember that reading of B + D should equal C. This is valid where driving and driven shafts are rotated together while checking alignment.

The quick check is useful for indicating improper procedures such as: sagging indicator brackets, dial indicator finger riding on flywheel chamfer, or indicator not properly positioned causing indicator to run out of travel.

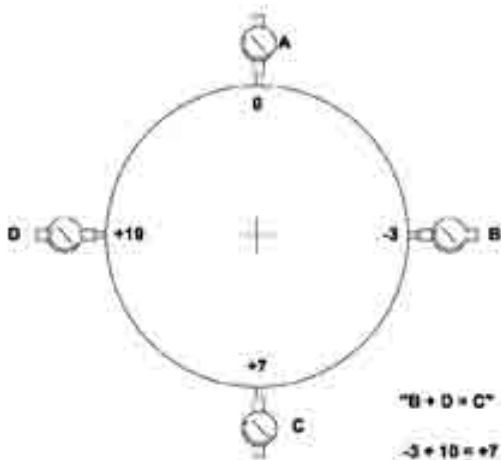
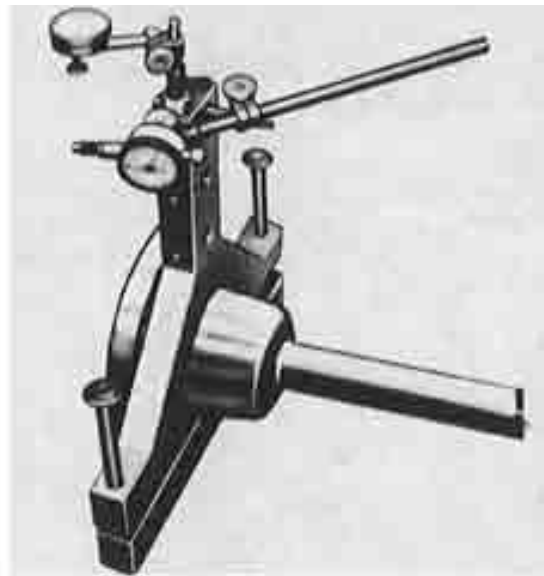

**Figure 6**

### Support Brackets

An indicator support bracket must rigidly support the indicator when fixed to one of the shafts and rotated. The support bracket allows location of the dial indicator at the measurement point. Proper brackets can be adjusted to work with varying driveline configurations. Refer to **Figure 7** for an example of an indicator support bracket.

Dial indicator brackets must not bend due to the weight of the indicator. Commercially available dial indicator brackets may not give adequate support when the indicator is rotated, causing false readings. Magnetic base dial indicator supports are not recommended.



**Figure 7**

To check support bracket rigidity, rotate the same configurations of bracket and indicator through a circle while indicating on the bracket side of the coupling. A maximum

reading of less than 0.025 mm (0.001 in) is allowed. It may be necessary to temporarily bolt a rigid reference arm on the bracket side of the indicator coupling to read against when taking an alignment reading.

Caterpillar recommends using the bracket, **Figure 7**, when performing

an alignment check. Use two 12.7 mm (0.50 in) diameter threaded rods or bolts to assemble the adapter. It may be necessary to fabricate different brackets when checking clutch alignments.

## Principles of Alignment

### Cold Alignment

Since there is no accurate or practical method of measuring alignment with an engine running at operating temperature and under load, all Caterpillar alignment procedures must be performed with the engine stopped and the engine and driven equipment at ambient temperature. This is called "cold alignment." In order to achieve correct operating alignment, certain factors must be taken into consideration in determining cold alignment specifications. Depending on the application, some or all of the following factors will affect the cold alignment procedure.

### Hot Alignment

In the past, a hot alignment check may have been used to check the accuracy of the cold alignment procedure. However, factory tests have shown that the results of the hot alignment check are inconsistent; therefore, this procedure is not recommended except for G3600 engines. Please refer to the G3600 Commissioning Guide for the G3600 Hot Alignment procedure.

### Crankshaft Position

Alignment is made under static conditions while the crankshaft lies at the bottom of its bearings. This is not its position during operation. Firing pressures, centrifugal forces, and engine oil pressure all tend to lift the crankshaft and cause the

flywheel to orbit around its true center. Refer to **Figure 8**.

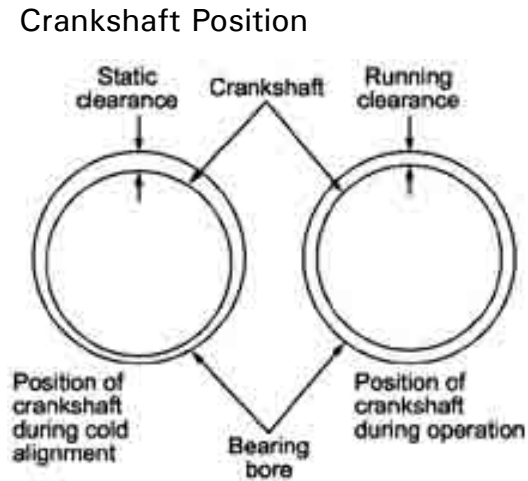

**Figure 8**

Generally, driven equipment will have ball or roller bearings that do not change their rotational axis between static and running conditions.

### Flywheel Sag or Droop

With the engine not running, the flywheel and coupling cause a small deflection of the crankshaft. This results in the checking surface (pilot bore or outside flywheel diameter) rotating below centerline of the crankshaft bearings. For this reason, Caterpillar recommends alignment checks be performed with the coupling in place. Refer to **Figure 9**.

### Flywheel Sag or Droop

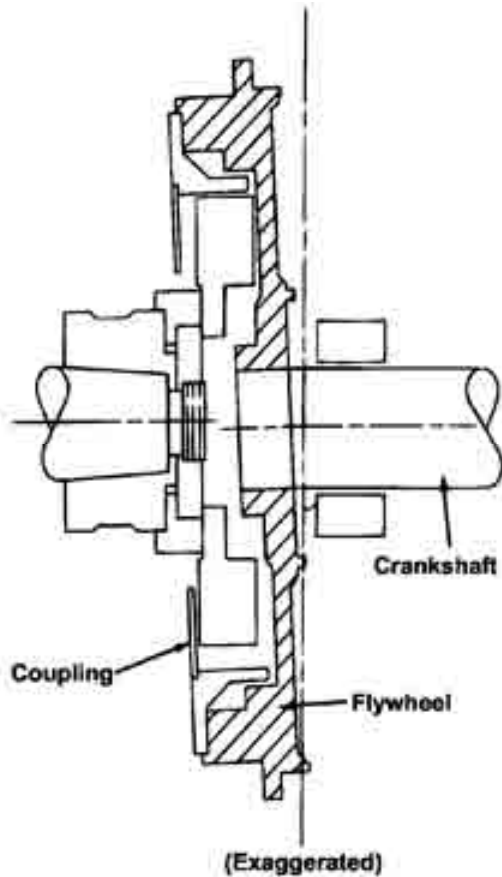

**Figure 9**

### Crankshaft Endplay

In all applications, after installation of the driven equipment the crankshaft endplay must not be less than it was before installation of the equipment. Crankshaft endplay should be checked during cold alignment and again after the engine is at operating temperature. Endplay at operating temperature must not be less than endplay during cold alignment.

Before taking indicator readings during the alignment procedure, always move the engine crankshaft

to the end of its endplay, toward the front of the engine, and the driven equipment shaft to the end of its endplay toward the engine. Do not use force against the crankshaft or driven equipment shaft while taking the indicator readings. After installation and alignment of the driven equipment, the crankshaft endplay must not be less than before the installation of the equipment.

### Crankshaft Deflection

Caterpillar engines mounted on bases not supplied by Caterpillar require a crankshaft deflection test.

This test can be performed on all Caterpillar engines equipped with crankcase inspection doors to assure the engine block is not unduly stressed. Perform the test under cold engine conditions before startup.

- Remove an inspection door from the block to expose the center crankshaft throw.
- Rotate the crankshaft in the normal rotation direction. When the cheeks of the center throw are past the connecting rods, install a Starrett No. 696 distortion dial indicator, or similar tool, as shown in **Figure 10**. As a precaution, tie a string to the gauge and secure it outside the engine to facilitate retrieval should the assembly fall into the oil pan.
- Zero the dial indicator's rotating bezel.
- Properly seat the indicator rotating it on its own axis until it will hold a zero reading.

- Rotate the crankshaft in the normal direction until the indicator reading at the bottom (plus or minus 45 degrees) is within a range of plus 0.03 mm (0.001 in) to minus 0.015 mm (0.0005 in).
- Rotate the crankshaft back to its original position. The indicator must return to its original reading of zero to make a valid test.
- If the gauge does not return to zero, the indicator shaft points were not properly seated and the test procedure must be repeated.
- If at any point other than the starting point the gauge reads more than stated above or the model specific limits stated in the Commissioning Guide, then cylinder block distortion has occurred due to improper mounting.
- To correct the problem, loosen hold-down bolts between engine rails and mounting blocks.
- Re-measure all shims and adjust as necessary.
- Repeat distortion check procedure.

### Crankshaft Deflection

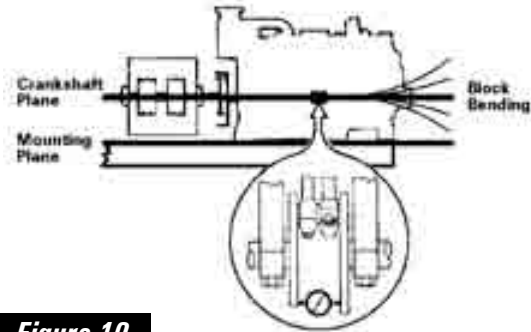

**Figure 10**

### Torque Reaction

The tendency of the engine to twist in the opposite direction of shaft rotation and the tendency of the driven equipment to turn in the direction of shaft rotation is torque reaction. It naturally increases with load and may cause a vibration. This type of vibration will not be noticeable at idle, but will be felt with load. This usually is caused by a change in alignment due to insufficient base strength allowing excessive base deflection under torque reaction load. This has the effect of introducing a side-to-side centerline offset that disappears when the engine is idled (unloaded) or stopped.

### Thermal Growth

As engine and driven equipment reach operating temperatures, expansion or thermal growth will occur. This growth occurs in all directions.

Vertical growth occurs between the component mounting feet and their respective centerlines of rotation. This thermal growth

depends on the type of metals used, the temperature rise that occurs, and the vertical distance from the center of rotation to the mounting feet. Refer to **Figure 11**.

Crankshaft horizontal growth occurs at the opposite end of the engine from the thrust bearing. This growth has to be planned for when driven equipment is connected to that end of the engine. The growth is slight if the driven equipment is bolted to the engine block, since the block and crankshaft grow at approximately the same rate. Refer to **Figure 12**.

Horizontal compensation consists of using a coupling allowing sufficient relative movement between driving and driven

members. The equipment must be positioned so the horizontal growth moves into the coupling operating zone, not away from it. One method is to position the engine crankshaft all the way forward (towards the front of base). Position the generator shaft back (towards the rear of the base) against thrust bearing. For generators without thrust bearings, the generator must be positioned in the magnetic center. Adjust generator to half (50%) of the total end-play of the generator and engine. Failure to do so results in excessive crankshaft thrust bearing loading and/or coupling failure. Sufficient clearance has been allowed if it is determined that the crankshaft still has end clearance.

### Vertical Thermal Growth

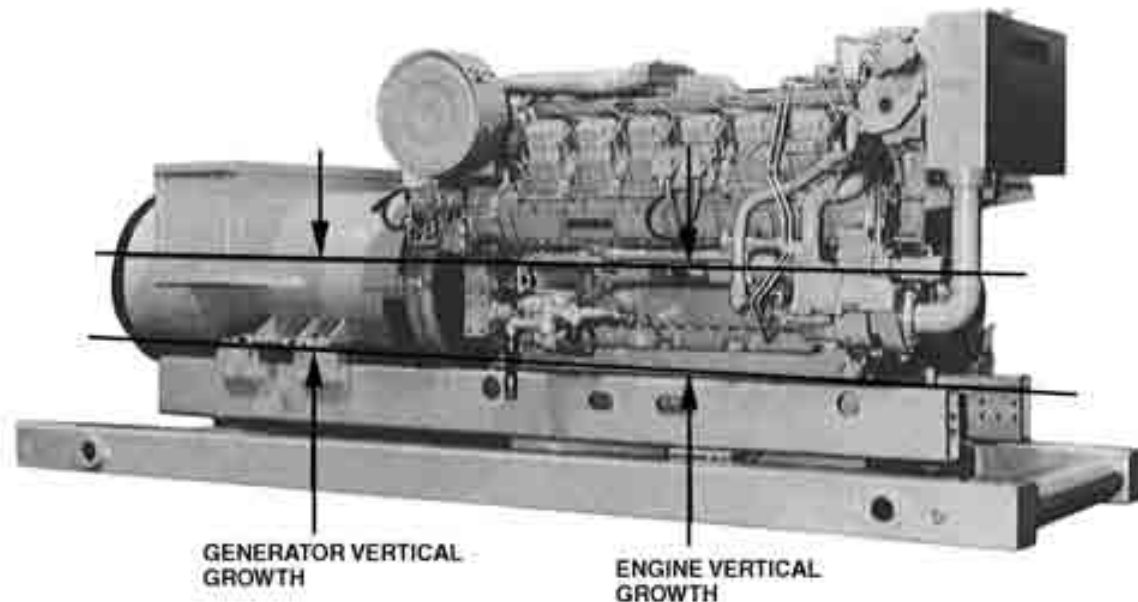

**Figure 11**

### Horizontal Thermal Growth

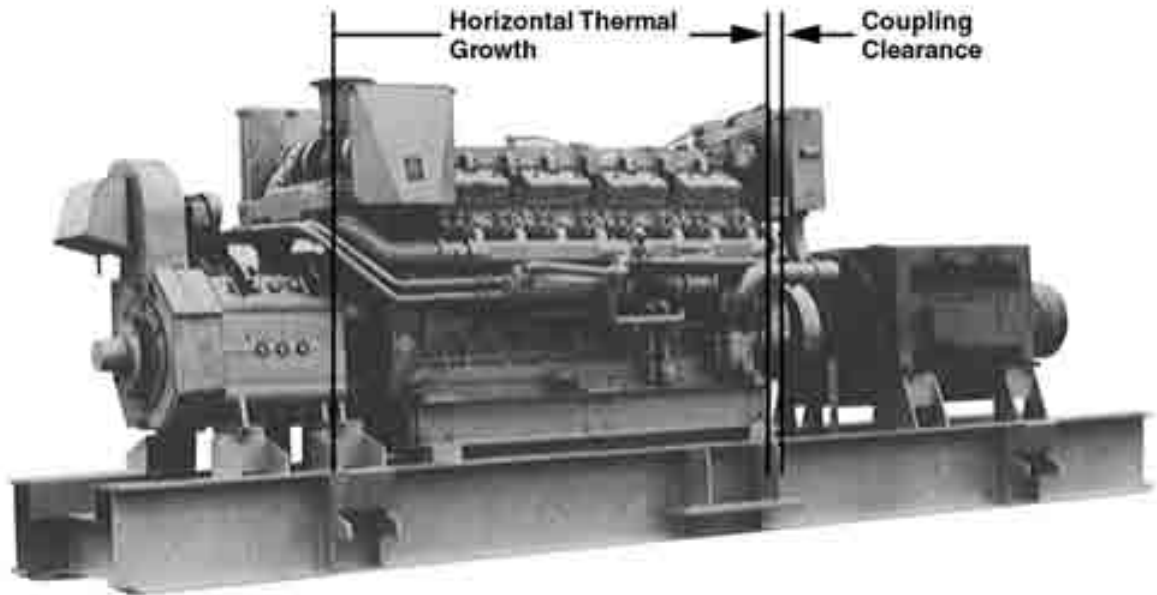

**Figure 12**

## Alignment Related Mounting Considerations

### Shimming

Shims can be used to obtain correct alignment between the engine and the driven unit. Depending on the application, shims are required under the engine, under the driven unit, or under the engine and driven unit. The most commonly used shim materials are metal or poured resin chocks. Under no circumstances should lead be used as a shim material. Lead is easily deformed under weight and vibration and has poor support characteristics.

### Metal Shims

After the engine and driven equipment have been aligned, install brass or some other type of non-

rusting metal shims between the mounting feet or mounting pads of the engine or driven unit and the base or other mounting surface.

**Important:** When metal shims are used between the mounting pads or feet and the base or mounting surface, the mounting surfaces must be flat, free of burrs, and parallel to the bottom surface of the mounting pads or feet.

Shim packs under all equipment should be 0.76 mm (0.030 in) minimum and 1.5 mm (0.060 in) maximum thickness to prevent later corrections requiring removing shims when there are too few or no shims remaining. Excessive thickness of shims may compress with use.

Shims should be of non-rusting material. Handle shims carefully. **Use only complete width and length shims, do not use partial shims trimmed to fit.**

After alignment, ensure each mounting surface is carrying its portion of the load by checking for soft foot. Maximum allowable soft foot is 0.0762 mm (0.003 in).

Failure to do this can result not only in misalignment, but also in springing of the substructure, high stress in welds or base metal, and high twisting forces in the engine or generator.

### Poured Resin Chocks

Pourable, epoxy based, resin chocking offers an alternative to the use of metal shims for alignment purposes. After pouring, this compound cures at normal temperatures to become an extremely tough and durable solid, providing the following advantages over metal shims.

- The time consuming and costly process of selective machining and hand fitting of solid steel shims is avoided.
- The surface condition or flatness of mating foundation and support planes is less critical, eliminating further machining operations in many cases.
- The plastic chocking material offers some degree of noise damping between the engine or driven equipment and the foundation.

- Zero shrinkage of the poured shim material, when mixed and applied properly, allows the most precise retention of position and alignment when the mounting procedure has been properly completed and the retaining bolts secured.

### Poured Resin Chock

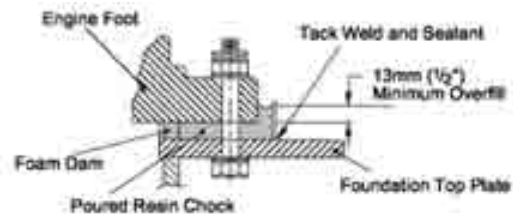

Section A-A Elevation

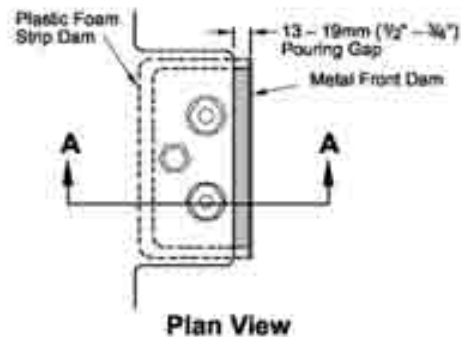

Plan View

**Figure 14**

### Vibracon Adjustable Chocks

Vibracon elements are self-leveling, height-adjustable machinery mounting chocks that can be used in place of metal shims and poured resin chocks. These chocks have similar advantages to the poured resin chocks along with several additional advantages.

- The poured resin chock curing time is eliminated, making the entire mounting and alignment procedure much quicker.
- The Vibracon adjustable chocks are reusable.

### Vibracon Adjustable Chock

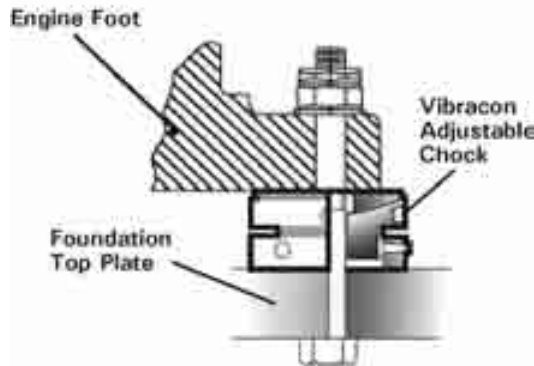

**Figure 15**

### Mounting Bolts

The diameter of the clearance-type bolts used to hold the engine rails or feet to the base must be 1.6 mm (0.06 in) less than the diameter of the holes in the engine rails. This clearance is to allow the engine mounting rails or feet to grow without confinement. Refer to the section on thermal growth.

### Mounting Bolt Torque

A bolt is properly torqued when it is stretched a calculated amount. The proper stretch clamps the driven device to the base securely. The clamp is then maintained during movement caused by vibration. An under-torqued bolt cannot maintain clamping force while vibrations are present. It will gradually work loose and allow misalignment to occur. Refer to **Figure 16**.

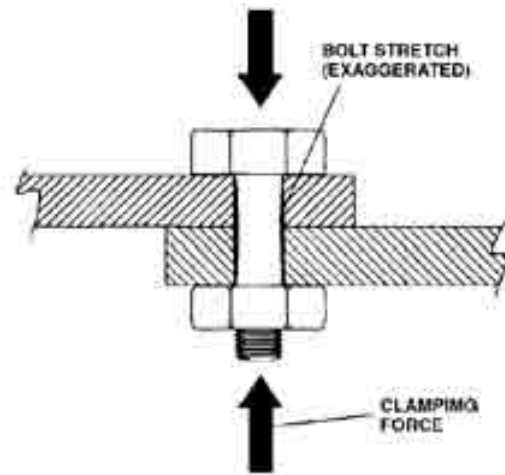

**Figure 16**

Bolts of the size used on Caterpillar oil field bases require very high torque values. As an example, a 25.4 mm (1 in) bolt has a torque of  $875 \pm 100 \text{ N}\cdot\text{m}$  ( $640 \pm 80 \text{ ft lb}$ ). A torque wrench, extension and torque multiplier are required to obtain this high value. Do not use special bolt lubricant; the effective bolt clamping force can be excessive. Refer to the service manual for bolt torque specifications. Any additional model specific mounting bolt torque recommendations are provided in the Commissioning Guide.

Caterpillar bolts are made of Grade 8 steel; one of the strongest available. Six raised or depressed lines on the nut or bolt head identify the bolts.

**Figure 17** shows the recommended torque for various Caterpillar bolts; however, these values may be too high for standard commercially available hardware.

**Procedure for Tightening Engine and Driven Equipment Mounting Bolts**

**Figure 17** shows the procedure used to verify that proper shimming of engine or driven equipment has been accomplished. This information is on a decal that is available to be added to packages. When the proper number of shims has been established, add or remove shims evenly when making alignment corrections.

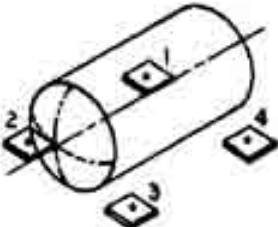

**Full Torque Values**

Bolt Diameter	Torque	
	lb ft	N·m
3/4	265 ± 35	360 ± 50
7/8	420 ± 60	570 ± 80
1.0	640 ± 80	875 ± 100

**Procedure for Tightening Equipment Mounting Bolts**

1. Torque bolts in sequence shown to 1/2 torque values listed above.
2. Install mounting yoke and indicator at top position instructed for axial alignment check.
3. Loosen bolt 1 and retorque bolt 3.
4. If indicator moves .002 in. (.05 mm) or less, retorque bolt 1 and follow step 5 and 6. If indicator moves more than .002 in. (.05 mm), add shims under bolts 1 or 3. Loosen all bolts and repeat steps 1 through 4.
5. Loosen bolt 2 and retorque bolt 4.
6. If indicator moves .002 in. (.05 mm) or less, retorque bolt 2. If indicator moves more than .002 in. (.05 mm), add shims under bolts 2 or 4. Repeat steps 1 through 6.
7. With indicator at top, retorque all bolts to full values. Reading should not change more than .002 in. (.05 mm).

**3N2021**

**Figure 17**

---

## Flexible Couplings

### General Requirements

A flexible coupling is a device used to transmit power from one shaft to another while accommodating some shaft misalignment. Some typical flexible couplings are:

- Couplings with rubber or elastomer elements.
- Couplings with flexible steel plates or discs.
- Couplings with spring type elements.
- Gear type couplings.
- Roller chain type couplings.

Flexible couplings can be used to connect an engine to a driven unit, two engines together, or several driven units together.

Four (4) distinct characteristics must be considered in the selection of a coupling.

### ***Misalignment Capability***

The coupling must be capable of compensating for some misalignment between two connected shafts. It is not the intent to correct for shaft misalignment, but only to compensate for small amounts of shaft misalignment normally present due to temperature fluctuations and operating loads.

### ***Stiffness***

The coupling must be of proper torsional stiffness to prevent critical orders of torsional vibration from occurring within the operating speed range. To ensure coupling compatibility, qualified personnel

should perform a torsional vibration analysis. If requested, Caterpillar can perform this analysis.

### ***Serviceability***

Ease of installation and service is a significant factor when selecting a coupling. If required, spacer pieces can be used to permit removal and installation of the coupling without disturbing the engine-to-driven equipment alignment.

### ***Coupling Selection***

In any installation, the coupling should be the design weak link or first part to fail. When failure occurs, the chance of damage to the engine and driven equipment is minimized. Safety measures must be considered to prevent major damage should coupling failure occur. The use of a standard, commercially available coupling offers the benefit of parts availability and reduced downtime in case of failure. When selecting a coupling, always follow the coupling manufacturer's recommendation regarding the best coupling for a specific application.

## Caterpillar Couplings

The three types of flexible couplings supplied by Caterpillar are:

- Flexible steel plate couplings are used in single-bearing generator applications.
- Spider and ring with rubber blocks are used in close-coupled marine transmission applications.
- Viscous-damped couplings are used with remote-mounted driven equipment and two bearing generators. These couplings use an internal gear design with a rubber element between the gears. Silicone grease aids in dampening characteristics. Clearances involved in internal gear design allow accurate alignment measurement to be made without removing the rubber element. Refer to **Figure 18**.

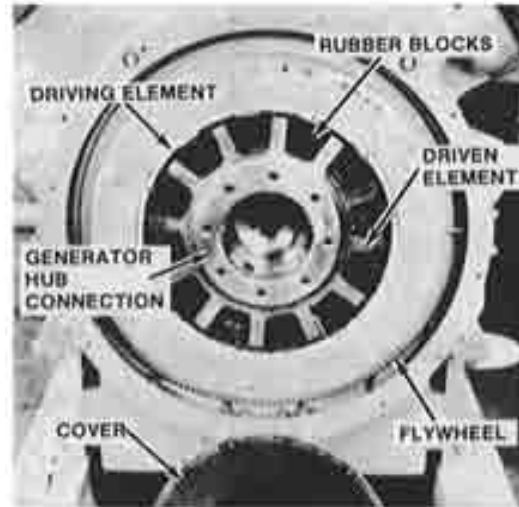

**Figure 18**

## Couplings by Other Manufacturers

Typical flexible couplings provided by other manufacturers use elements made of rubber or elastomer, and their stiffness can vary considerably. Therefore, it may be necessary to remove the flexible elements from the coupling in order to get valid indicator readings for the face and bore misalignment.

## Specific Alignment Considerations

As mentioned in the Alignment section introduction, Caterpillar provides Special Instructions with specific alignment procedures for all Caterpillar engine and driven equipment combinations. These procedures are listed at the end of this section under Reference Material and should be used for the actual alignment procedure, but the following offers some specific considerations relating to some of the more common applications.

### Alignment of Close-Coupled Driven Equipment

Close-coupled components, such as single-bearing generators, transmissions, compounds, etc., rely on bolting together of two piloted housings to determine alignment. When two piloted housings are joined together in a parallel manner, they are in alignment. However, outside stresses can be introduced by poor mounting practices and allow the flywheel housing to flex. This can contribute to high vibration.

To check for outside stresses, loosen the mounting bolts between the driven equipment and engine flywheel housing. There should be no contact between flywheel housing and driven equipment housing at this time to assure that neither housing is being stressed. Clearance between the two separated faces should be parallel within 0.13 mm (0.005 in). Refer to **Figure 19**. Oil field generators are extra heavy and may distort the

flywheel housing when it is not parallel to engine.

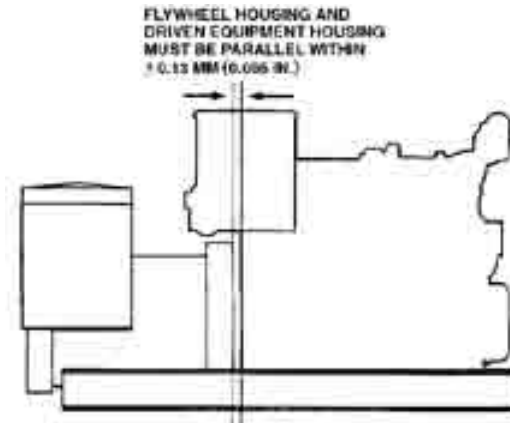

**Figure 19**

To avoid this, make sure there is a minimum 0.13 mm (0.005 in) gap for the full 360° when making this parallelism check.

A dial indicator mounted between flywheel and generator rotor is sometimes used to check alignment. However, after the generator housing is piloted into and bolted to the flywheel housing, alignment is not checked by the dial indicator method.

When the dial indicator method produces results in conflict with the parallelism check of the two housings, see **Figure 21**, such conflict indicates the rear bearing of the driven equipment is not centered in relation to the engine, and is subject to generator manufacturer's accepted tolerances, flywheel housing nominal runout, and flywheel droop.

Do not shim generator mounting feet after the generator housing is bolted to the flywheel housing. Such practices stress both the generator housing and flywheel housing and can cause vibrations.

It is not necessary to make this check on smaller Caterpillar generator sets where the engine does not have rear mounting feet but relies on the generator set support. However, this check is necessary on smaller Caterpillar engines where the driven equipment is also rigidly connected to another piece of equipment. A common example of this would be a mechanical drive where the clutch mechanism is bolted to the compound. Poor mounting practices with this arrangement can cause excessive stresses in the flywheel housing.

Single bearing generators are recommended to have a pilot shaft extension and loose fitting flex plates, or no pilot shaft extension with piloted plates. This aids in maintaining proper alignment.

If vibration is noted at assembly of a generator having coupling plates piloted into the flywheel, repositioning the coupling plates  $\frac{1}{4}$ -of-a-turn with respect to the original location can often correct the vibration. Start the unit and observe the change in vibration. A second or third relocation may be necessary to find the position of lowest vibration. Locate plates at point of lowest vibration. This procedure allows manufacturing tolerances to attempt to cancel each other.

Before bolting coupling plates onto the flywheel, always rotate engine to the same position. For example, cylinder number 1 TDC. Tighten half the bolts while the flywheel is in this position. Then rotate as necessary to tighten other bolts. This procedure assures that any sag in the crankshaft is always at the same position when the plates are fastened to the flywheel.

### **Alignment of Remote Mounted Gear Driven Equipment**

Perform final alignment after all major equipment has been installed on the base. Engines and driven equipment should be filled with oil and water as required and ready to operate.

Remote mounted gear drive units must be supported by the same base or rails as the engine as shown in **Figure 20**. These units are not fastened to the engine except through a drive shaft and flexible coupling. To install these units, the gear drive must first be aligned with the equipment that it is driving. Then the engine must be aligned with the gear drive unit.

Alignment between the gear drive unit and its driven equipment is usually line-to-line alignment. The centerline of the gear drive output shaft is in line with the centerline of the input shaft of the driven equipment. Depending upon the application, it may be necessary to use a flexible coupling between the gear drive unit and the driven equipment.

## Alignment Considerations

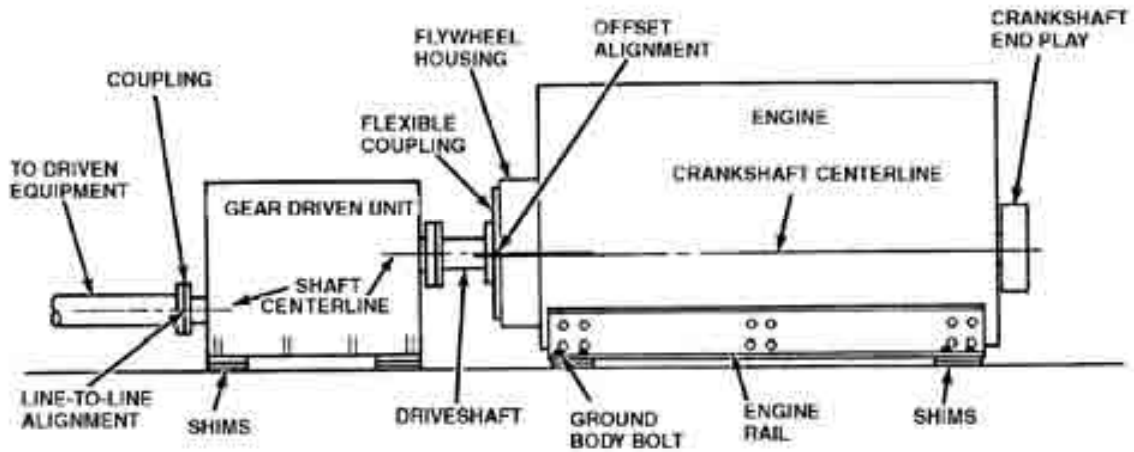

**Figure 20**

The allowable misalignment between the output shaft of the gear drive unit and the input shaft of the driven equipment must be within the coupling manufacturer's tolerances.

Use shims as necessary between the mounting pads of the gear drive unit and the base to put the gear drive unit in alignment with the driven equipment. There must be solid contact between the mounting pads and the base at all locations without the anchor bolts installed. If all mounting pads are not solidly supported, distortion of the gear drive unit may result when the anchor bolts are tightened.

Alignment between the gear drive unit and the engine is always an "offset" alignment. The centerline of the engine crankshaft is positioned below the centerline of the gear drive input shaft. This compensates for the thermal growth of the engine, flywheel sag and main bearing clearance during cold

alignment. With this vertical "offset" in the cold condition, the crankshaft and gear drive input shaft will be incorrect alignment at operating temperature. Because of this "offset" alignment, the coupling between the engine and gear drive unit must be a flexible coupling.

After the engine is in correct alignment with the gear drive unit, install shims as necessary between the engine rails and base to maintain this alignment. There must be solid contact between the rails and base at all mounting locations before installation of the anchor bolts. If there is not solid contact, the engine cylinder block can be stressed when the anchor bolts are tightened. Use a fitted bolt at the right rear corner between the rail and the base to direct horizontal thermal growth of the engine away from the coupling. Use clearance bolts at all other locations.

When clutches are used that contain air bladders, pay careful attention to air pressure; the allowable amount of misalignment goes down as air pressure increases. Alignment limits must not exceed limits established for a Caterpillar viscous dampened coupling or for the clutch, whichever is smaller.

Clutches are to be disengaged when alignment is checked. Refer to **Figure 21**. Rotate clutch slowly through 360° (6 radius) and check total indicator reading at 90° (1.5 radius) intervals. Shim the engine as required to achieve correct alignment. Refer to **Figure 3** for misalignment examples.

**Alignment Check**

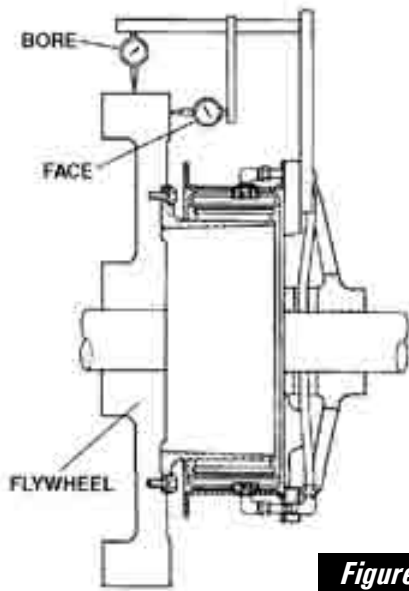

**Figure 21**

The dial indicator reading will include an error due to runout of clutch or flywheel parts. Where excessive runout is suspected, check and correct as required.

**Drive Shafts**

Some drives, such as U-joint couplings, have different operating angle limits for different speeds.

As a general rule, the angle should be the same on each end of the shaft as shown in **Figure 22**. The yokes must be properly aligned and sliding spline connections should move freely. If there is no angle at all, bearings will be subject to brinell damage due to lack of movement.

**Universal joint shaft drive**

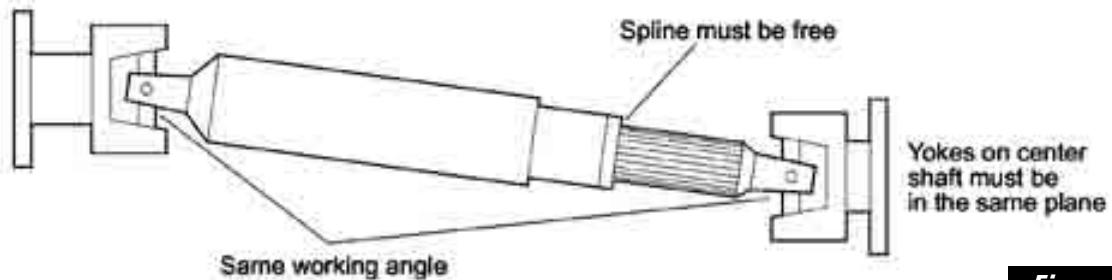

**Figure 22**

---

## Reference Material

The following information is provided as an additional reference to subjects discussed in this guide.

**SEHS7073 (3500)**

Special Instruction - Alignment of Two Bearing Generators

**SEHS7259**

Special Instruction - Alignment of Single Bearing Generators

**SEHS7654**

Special Instruction - Alignment - General Instructions

**REHS0177**

Special Instruction - Alignment of Close Coupled Two Bearing Generators

**REHS0204**

Special Instruction - Procedures for the Installation and Initial Start-Up of Gas Engine Chiller Drivelines

**REHS0423 (3600)**

Special Instruction - Alignment of Two Bearing Generators

**REHS0445**

Special Instruction -Alignment Procedures for G3500 Tandem Generator Sets

**REHS0475**

Special Instruction - The Installation and the Alignment of the Two Bearing Locomotive Generators



