



Electric Power Application and Installation Guide

Generator System

LEBX0025



WHERE THE WORLD TURNS FOR POWER

Table of Contents

Basics of Electrical Generation	5
Main Components of a Generator	5
Magnetic Field and Voltage	7
Phase and Voltage	7
Generator Design	8
Rotor	8
Stator	9
Windings	10
Insulation Systems	12
Rotor Insulation	13
Stator Insulation Combinations	13
Insulation Life	14
Coil Connections	16
Generator Features and Attachments	18
Physical Data	18
NEMA & IEC Design Considerations	20
Maximum Momentary Overloads	20
Maximum Deviation Factor	21
(TIF)	21
Short Circuit Requirements	21
Overspeed	21
Generator Performance Characteristics	22
Rated and Per Unit	22
Efficiency	22
Fault Current/Short Circuits	23
Reactance	25
Transient Reactance ($X'd$)	26
Sub-Transient Reactance ($X''d$)	27
Synchronous Reactance (X_d)	29
Negative Sequence Reactance (X_2)	29
Zero Sequence Reactance (X_0)	29
Harmonics & Distortion	30
Miscellaneous Terms	33
Generator Limits	33
Exciter & Regulator Characteristics and Performance	34
Excitation System	34
Voltage Regulation	35
Performance	37
Specifications	38
Frequency Sensing	39
Type	39

Generator System

Caterpillar's well-proven, innovative generator designs have led to several highly reliable lines of generators used in electric power generation applications worldwide. From offshore oilrigs to natural gas fields, from remote areas to urban confines — wherever there's a need for clean, efficient, reliable power — there's a Caterpillar generator capable of doing the job.

This module is designed to provide you with the basic concepts involved in the various Caterpillar generator designs. It is broken into sections including basic electrical generation concepts, generator design and performance as well as discussion on voltage regulation. As you go through this module, keep in mind that the information refers primarily to synchronous generators. Synchronous simply means that the rpm of the prime mover (such as an engine) and the output frequency of the generator are exactly proportional.

All Caterpillar electric sets use AC generators. The AC generator — also referred to as an alternator — converts mechanical energy to electrical energy and acts as a voltage source for the load.

Electricity is a useful source of energy because it is so versatile (much more versatile than mechanical energy). It can be used for lighting, heating, rotating electrical machinery, etc. and can be used in a variety of locations.

Basics of Electrical Generation

There are three basic requirements for the generation of voltage: magnetism, motion, and conductors. The generator system is based on the concept that when a coil moves relative to a magnetic field, a voltage is produced. You may remember that when a conductor cuts through a magnetic field a current is produced in that conductor. These two concepts are very closely connected. Also, keep in mind that it makes no difference whether the magnetic field is stationary and the conductor moves or whether the

conductor is stationary and the magnetic field moves. There just needs to be relative motion.

The simplest generator consists of a loop of wire rotating between two permanent magnet poles.

Main Components of a Generator

An AC synchronous generator is significantly more complex than the simple generator of a wire loop rotating between two permanent magnets. An AC synchronous generator consists of four main components and/or systems:

- Field (rotor)
- Armature (stator)
- Exciter
- Automatic Voltage Regulator

Essentially the process of generating voltage goes in the following order. The exciter provides DC current to the rotor windings. DC current through these wires creates flux. This flux generates voltage in the nearby stator windings when there is relative motion between the two. The regulator then senses this output and controls the exciter current.

In Caterpillar generators, the rotor (the source of the magnetic field) rotates inside a stationary armature called a stator. One reason for using a stationary armature and a rotating magnetic field is the difficulty of taking 3-phase current from a rotating armature. The rotor is rotated by a prime mover. In the case of Cat gen sets, the prime mover is almost always an engine.

The **rotor** contains magnetic poles with windings wrapped around them to form coils. These coils are called field coils or field windings because they create a magnetic field when excited with a DC current. Typically the field windings in a generator contain several hundred turns.

A magnetic field radiates out from the rotor as lines of flux. As the rotor rotates, so does the magnetic field. When this moving magnetic field comes across a stator winding voltage is produced. The magnetic field is strongest at the north and south poles where the lines of flux are concentrated. Therefore, the closer a pole is to a stator winding, the higher the voltage produced in that stator winding.

The symmetrical design of the generator ensures that the rotor poles extend over equal arcs and that the flux density distribution is similar across all stator windings.

Magnetic **poles** refer to the magnetic north and south and are the points where the magnetic field is strongest on the rotor.

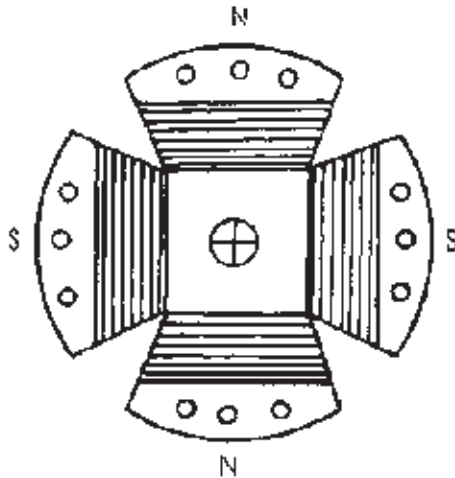

Figure 1.

A pole relates to the number of magnetic poles developed in the rotating field. Magnetic poles in a four-pole generator are arranged north-south-north-south around the circumference of the rotor. The number of poles (north-south-north-south) and the desired **frequency** (cycles per second or hertz) determine the **synchronous** or **no-load speed** in revolutions per minute (rpm):

$$\text{rpm} = \frac{120 \times f}{\text{number of poles}}$$

If 50 Hz is desired from a four-pole generator, the generator must be driven at 1500 rpm. A six-pole generator is driven at 1000 rpm:

The generated frequency of 50 Hz is entirely a function of the driven speed.

$$1000 \text{ rpm} = \frac{120 \times f}{6} \quad f = 50$$

The relationship between the number of poles and the synchronous speed is shown in the table below. These calculations are figured by taking the fundamental frequency of 50 or 60 Hz and dividing it by the number of pole pairs. It is then multiplied by 2π to get the synchronous speed into rad/s that is then converted into rpm.

Synchronous Speeds			
60 Hz		50 Hz	
Poles	Rpm	Poles	Rpm
2	3600	2	3000
4	1800	4	1500
6	1200	6	1000
8	900	8	750
12	600	12	500

Table 1.

Regardless of the number of pole pairs, the rotor moves 360 mechanical degrees in one revolution. In electrical degrees, however, each pole pair rotates 360 mechanical degrees. In other words, electrical degrees are the mechanical degrees times the number of pole pairs. In a four-pole generator (two pole pairs), each pole pair moves 360 mechanical degrees, so the total electrical degrees moved is 720 (or 360×2).

Mech. Degrees \times No. Pole Pairs
 2-pole: 360° electrical
 4-pole: 720° electrical
 6-pole: 1080° electrical
 8-pole: 1440° electrical

The main **armature**, or the stator, remains stationary. The **stator** consists of the stator core, exciter field coils, and its own windings called stator windings, or armature windings. The stator windings are placed in slots along the inside of the stator. The stator usually contains a large number of slots. The rotor magnetic field cuts across the stator windings as it rotates inside the stator. As a result, voltage is produced in these windings. The closer a winding is to a pole face on the rotor, the point where magnetic field is the strongest, the higher the voltage produced in that stator winding. The stator voltage is the generator output that is supplied to the load.

Magnetic Field and Voltage

The magnetic field is induced in the main generator by a DC current from the exciter through low voltage field or rotor windings. These windings are low voltage compared to the stator windings. DC voltage as high as 250V is often used in larger generators, while smaller and medium sized generators seldom use voltages higher than 125V.

Because it is so difficult to extract high voltage from a rotating armature, the magnetic field of the main generator is rotated rather than the armature. Occasionally a rotating armature generator will be used as an exciter in Cat generators.

Generator output voltage depends on the following:

- Speed of relative motion between magnetic field and stator conductors
- Strength of magnetic field
- Number of series turns in the stator windings

The **strength of the magnetic field** is proportional to the current flowing through the field coils. As the current rises, the magnetic field grows stronger.

The **speed of relative motion** between the magnetic field and the stator windings depends on the rotational speed of the rotor (engine rpm). As the rpm rises, so does the speed (V) of relative motion. The higher the speed of relative motion, the greater the generators output capabilities.

Voltage can be adjusted by arranging the stator windings in coils and varying the number of **turns**, or times the windings are wound around the stator. The higher the number of turns, the higher the voltage induced. The lower the number of turns, the lower the voltage induced. Hence, stator windings can be arranged with the optimum number of coil turns to produce the required output voltage.

Phase and Voltage

This section demonstrates the ways in which phase, voltage, and the stator core are all inter-dependent. The calculated design of the stator core and winding distribution enables a generator to provide the appropriate output voltage.

The phase voltage of a generator is directly linked to the voltage output of that generator. The type of voltage induced is partially dependent on the number of phases in a generator.

A **single-phase generator** will generate a voltage sine wave when the rotor completes one cycle (one 360° revolution).

A **three-phase generator** consists of three coils equally spaced around the stator and connected in a wye (Y). Therefore, three voltages can be produced consecutively with a 120° phase difference.

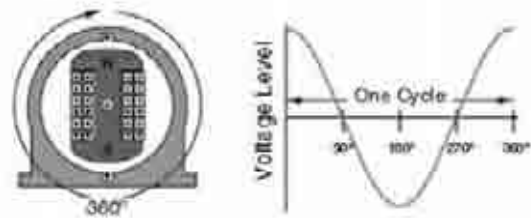

Figure 2.

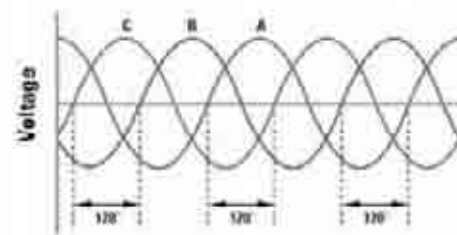

Figure 3.

In three-phase generation, three phases of voltage are produced 120° apart. However, to make the connection a symmetrical 3-phase connection, the B phase coil for example, has an equal and opposite winding 180° away, referred to here as -B. The result is that the three phases and their opposing windings are actually 60° apart.

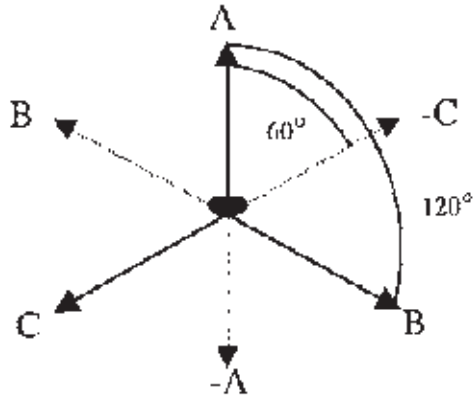

Figure 4.

Generator Design

Generators are constructed in various ways to satisfy different load and customer requirements. At **prime** power, the generator itself is rated on a continuous duty (24 hours per day) basis. **Standby** generators, used many times for back-up power needs, are rated on a temporary use basis. The rating is expressed in kilowatts at 0.8 power factor. A common ratio, kW divided by 0.8 permits calculation of kVA on all generators.

Rotor

The rotor is defined as any rotating winding or element of a generator. It can be described as an assembly of thin magnetic steel laminations, tightly compressed and then riveted, bolted or welded together to form a magnetic path. It is around this core that the **field windings**, or coils of conducting material, are wound around or inserted.

Amortisseur Windings, also known as **dampener windings**, are special conducting bars laid into a squirrel cage configuration. They set in the notches in the rotor and then are shorted on the end by either a shorting ring or shorting laminations. They are used to increase machine stability. This is due to the windings and rotors relationship to the synchronous speed. If the rotor is at synchronous speed, there is no induced voltage through the amortisseur bars, hence there is no interaction. Conversely, if there is a differential between the rotor and synchronous speed, a voltage will be induced in the windings. This voltage produces a current flow and in turn creates a magnetic field. The interaction of the two magnetic fields in turn causes a torque that will correct this speed difference resulting in speed and torque stability.

Non-Salient is a physical description that describes a cylindrical rotor. But if the rotor's pole faces project out from it, it is said to have **salient** poles.

The rotating salient pole field arrangement is affected by Reluctance torque and is used for engine-driven generators on most machines in the 20 kVA (16 kW) and larger sizes.

A rotating non-salient pole field, or cylindrical rotor, isn't affected by Reluctance torque and it is mainly used for large, steam turbine-driven generators and occasionally with water-cooled armatures. The non-salient configuration usually has grooves cut into the pole faces to place the windings.

A **permanent magnet field** eliminates the need for an exciter and therefore is very cost effective in smaller size generators. The disadvantage to this is that it's flux density (field strength) is constant and voltage regulation is poor. However, if it is to be used in an application with a steady load and minor fluctuations, a PM field can be very effective.

A **rotating armature, stationary field** generator is used mainly in small, low-voltage machines. A common use for this generator is as an exciter for brushless generators.

Stator

The stator is defined as any stationary winding or element of a generator. The stator core is where the usable electricity is generated. The windings carrying the usable electricity are placed in the stator core slots.

The stator core is made up of hundreds of 0.0185 in. to 0.025 in. thick steel **stampings**/ laminations stacked together. Stacking machines use automatic welding to assure correct stator skew, stack pressure, and slot alignment. Stator stampings are usually stamped from special silicone steel. The stator core is subjected to an alternating flux which induces currents, called “eddy currents”, in the core that create losses. Creating the core from stacked stampings rather than from one solid piece of steel inhibits eddy currents, reducing losses. The silicone added to the steel stampings and an oxide coating also helps to inhibit eddy currents.

In addition to eddy current losses in the stator core, there are hysteresis losses. Hysteresis is “the failure of a property that has been altered by an external agent to return to its original value when the cause of the alteration is removed.”

The B-H curve shows that unmagnetized iron starts at 0 and proceeds to saturation as the magnetomotive force (MMF) increases. In simpler terms, the unmagnetized iron becomes magnetized. As MMF is reduced to 0 again (or as the iron loses its magnetism), a residual B' results. The residual B' means that the iron does not entirely lose its magnetism when MMF hits 0. The same curve loops around as MMF becomes negative then positive again from an AC exciting current. Since the hysteresis loop results in internal domain realignment, energy is expended. Losses are proportional to the area of the loop created due to the work expended in following through the cycle of magnetization and demagnetization.

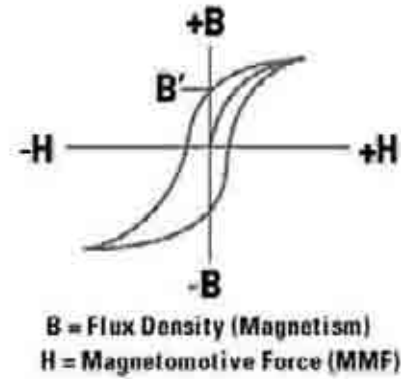

Figure 5.

This **core loss curve** for M-43, 24 gauge, hot rolled steel shows how core loss increases with increasing induction at 50 Hz and 60 Hz. The core losses measured in this curve include both eddy currents and hysteresis.

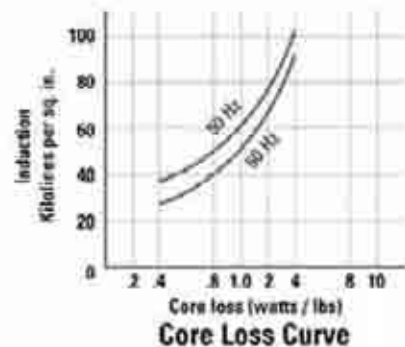

Figure 6.

The output capability of a generator is measured by a number of attributes, one of which is the physical size of the stator core. The inside diameter (called the air gap diameter) and the inside core length are among a number of attributes related to the kVA output. The **air gap** area is found in the stator core. It is simply the area inside the stator core. This area is found by multiplying the core circumference (pd) times the core length (l). The flux density of the air gap (B_g) is then the total flux (ft) divided by the inside core area.

The magnetic flux in the air gap is created by the field windings on the rotor. The rotor laminations are not necessarily made of the exact same material as stator laminations because the flux in rotor laminations is uni-directional, always flowing out of the north and into the south magnetic poles. The only critical areas for loss in the rotor are the pole faces, which receive alternating flux across the air gap from the stator.

Different loads require different types of voltage. Generators are designed with various combinations of slot, conductor, and winding types to provide the specific kind of voltage required by the generators' loads.

Stator stampings contain one of two kinds of winding slots. The semi-closed slot accepts only a random winding, meaning one wire at a time is fed into the slot. The open slot accepts a random winding or a form-wound winding. The entire coil is placed into the slot, rather than being inserted wire by wire. Double-layer winding consists of two coil sides per slot, resulting in the same number of coils as slots. Shown are both a random wound, semi-closed slot cross-section and a random wound, open slot cross-section.



Figure 7.

Windings

Stator Winding processes can be broken down into two types, the routing of the coils, concentric versus lapped, and the winding type, random versus formed.

There are three winding styles: lap, wave, and concentric. The most common styles are lap and concentric.

Lap windings are loops routed across one another and wound into a double diamond shape. An entire coil group can be wound at one time. Therefore, connections are made only at the coil group, not at each coil. An insulation material called a phase sheet, which increases the creepage distance, separates each coil group. Lap winding is a double-layer winding. There are two coil sides per slot, resulting in the same number of coils as slots. Surge rope and tape are added to end turns to hold the end turns stationary during surges, motor starting, and transients. The surge rope, which is made with a strong fiberglass and epoxy, also reduces deformation of the end turns when they are stressed. The tape additionally serves to protect the coil end turns from abrasion between coils.

Concentric windings are wound into loops within larger loops. This results in the simplest mechanical assembly, least amount of copper but also slightly higher levels of harmonics. This winding style is the most economical and allows an entire coil group to be wound at once and machine inserted. Like lap winding, connections are made at the coil groups, not at each coil. Concentric winding is a single-layer winding. There is one coil side per slot, resulting in twice as many slots as coils. Phase sheets are placed between the phases to provide extra insulation between coil groups. Phase sheets are placed between phases in lap wound generators, as well. Shown below are examples of both lap and concentric windings.

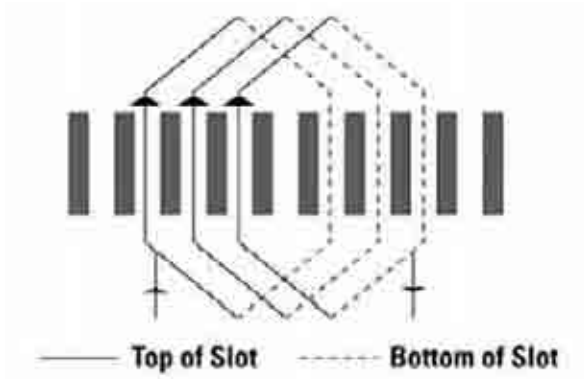

Figure 8.
Lap Wound

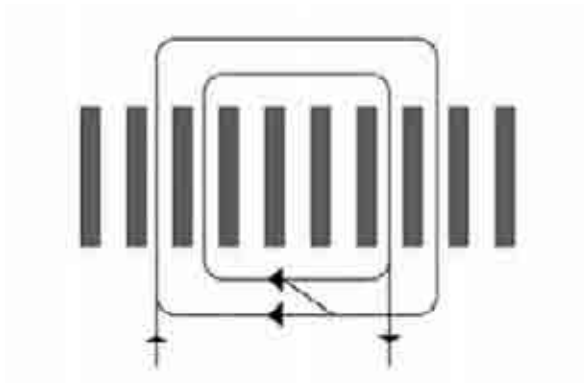

Figure 9.
Concentric Wound

When a coil is wound 180 electrical degrees, the voltages on the conductors on either side are equal in magnitude and opposite in direction and are said to be a full **pitch** coil. Sometimes a coil is wound less than 180° and is said to be a fractional pitch coil. The reason for this is to reduce certain harmonic factors that will be discussed later in this module. Delta connections in larger generator sets (above 250 kW) are required to be set in a 2/3-pitch configuration due to high harmonic current content.

Random windings utilize coils of round wire. Material costs are lower, but this method leaves spaces between the individual wires. **Formed** windings utilize square or rectangular wires which can be placed very close to one another, resulting in the maximum amount of copper, least amount of spaces, and, therefore, superior efficiency and durability. The superior efficiency being due to reduced

amount of air space, which has a higher reluctance, the force that opposes magnetic flux. While concentric windings and lap windings may be either random or form wound, form windings are usually impractical for smaller kW (under 250 kW) generators because of inadequate spacing.

The two winding types are shown below:

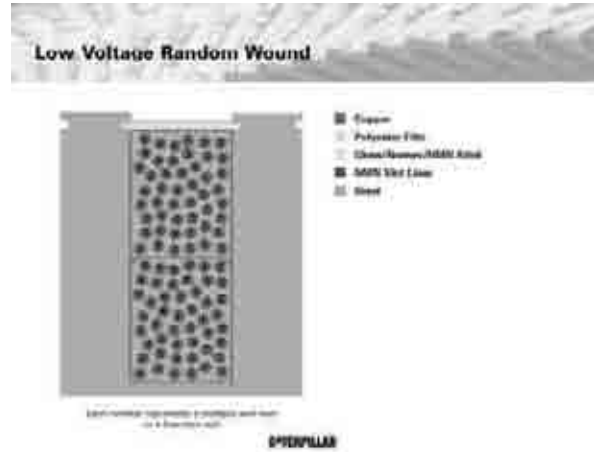

Figure 10.
Random Wound

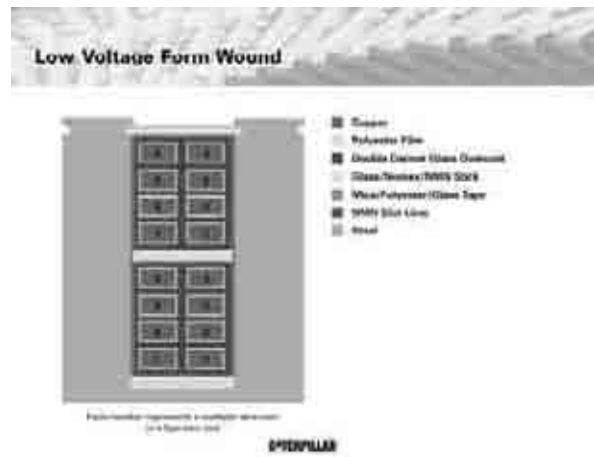

Figure 11.
Form Wound

Random wound coils are wound with round copper magnet wire that is insulated with a moisture resistant heavy polyester film and amide-imide overcoat. Containing multiple conductors per turn, the coils consist of one or many turns each and are wound in a double diamond shape. Random wound coils

are cost effective and are suited for low power ratings, standby applications, clean environments, and low operating hours.

The random wound stator is treated using a dip and bake process. The stator is dipped and totally submerged into a polyester resin. Polyester resin is used for its superior heat dissipation, flexibility, voltage breakdown strength, and moisture resistance. The resin penetrates the spaces between the conductors and leaves a uniform resin build. The resin is then cured by a bake cycle. By holding the conductors together, the resin prevents vibration and premature failure. Next, the stator is dipped and baked using an epoxy resin. The epoxy adds extra protection against moisture, chemicals, and other environmental factors. If requested and/or necessary, additional dips and bakes maximize resin buildup and environmental protection (up to 2 to 4 dips and bakes). Asphalt epoxy can also be applied to the lead end to further protect against abrasion and moisture. All random wound stators are sprayed with red sealer to help retard voltage tracking and to seal all parts from rust and corrosion. Tracking is caused by contaminants like salt water, which can get trapped on the coil end turns. Surface currents then develop and carbonize or “track” the resin surface.

Coastal insulation protection is sometimes added to random wound windings for increased environmental protection. The end turns are the most susceptible to moisture and contaminant buildup, so glass tape is added to the end turns to aid in extra uniform resin retention capability. The tape also makes coil end turns smoother, retarding moisture and contaminant buildup. Finally, along with the normal dip and bake process, an extra epoxy dip and bake is done.

Form wound coils are pre-formed with rectangular copper magnet wire and taped with multiple layers of fused double daglass over heavy film polyester with an amide-imide overcoat. The coils are taped to add mechanical strength. The number of tape layers varies depending on the voltage applied to the coil and the dielectric strength (ground insulation) needed. Additional protection can be added if required because of environmental

factors. Mica tape is used for ground insulation because of its insulating properties, such as: high dielectric strength, high breakdown voltage, high insulation resistance, and excellent protection against moisture, chemicals, and other environmental factors.

Open stator slots allow the coils to be placed in the slots without separation of the wires within the coils. Coils are connected either by groups or by individual coils with both crimp connections and soldering. Connections are taped and sleeved to assure a good seal against environmental factors.

Because form wound coils are pre-formed, air space exists between each coil in the coil head, allowing better cooling. Each coil head is also braced with double surge ropes and other blocking between coils to prevent coil movement during surges and other transients (e.g. sudden load changes and switching).

Form wound stators are **Vacuum Pressure Impregnated (VPI)** for added protection from the environment. After the connecting and brazing stages of the insulation process, the entire stator winding and core assembly is vacuum pressure impregnated with a special polyester resin varnish. VPI is a process where air is removed causing the resin and other coatings to adhere more tightly to the windings. This process was developed specifically for form wound windings.

The cost of manufacture, from lowest to highest, is concentric/random to lapped/formed, with durability and quality of electricity in the same order. Cat Generators have been designed in accordance with the expected application. High output prime power generators are lapped/formed. Medium output prime and high output standby use random/lapped.

Insulation Systems

This section explains the importance of a properly functioning insulation system in a generator. The insulation system is a complex combination of insulation materials that are carefully selected by the generator designer to prevent undesirable electrical flow.

This segment discusses the different kinds of windings used in generators and the characteristics of those windings.

Generators consist of three types of material: copper wire, iron, and insulation. To function properly, the individual copper conductors in stator windings must be completely insulated from neighboring conductors in the same coil and from the surrounding iron (referred to as ground).

Insulation must prevent electrical breakdown between components, but must also be used as sparingly as possible. Less insulation means more space available for copper and better heat dissipation. More copper and better heat dissipation improves maximum output from the generator. More or higher quality insulation is necessary in higher voltage machines due to the added stress put on the material.

Rotor Insulation

Each Cat rotor is precision layer wet wound. This means the conductors are hand-placed precisely in rows, layering one row on top of the other. Each layer of conductors is brushed with high bond strength epoxy before the next layer is added to assure a good seal between conductors.

Since the field coils employ a low voltage, field coil insulation problems are mostly mechanical. As the rotor rotates, centrifugal force is applied to the field coils causing the coils to bow out. When centrifugal force is broken down into its components, there is a vertical force (FV) and a side force (FS). It is the side force that causes the coils to bow out.

To prevent field coils from bowing out due to centrifugal force, wedges are placed in-between the poles with their two sides holding the coils tightly against the poles. Extra wedges and bracing are sometimes added for extra assurance that rotor materials do not move. The numbers 1 on the photo indicate wedges.

The purpose of the Amortisseur or damper windings (discussed earlier) is to prevent rotational oscillations in the rotor. These windings provide a motoring effect and produce a torque in the rotor working against such oscillations, thereby providing superior voltage stability. This is particularly important during parallel operation where generators carrying uneven loads can result in voltage and operational instability which translates to added stress on the Insulation. Damper windings will minimize or “dampen” these oscillations. Damper windings also “dampen” oscillations occurring from short-circuit and engine pulses.

Tests are performed on the rotor to assure that there is no material movement in the rotor. A prototype spin test runs at 150% rated speed for two hours at 170° Celsius. In addition, each rotor in production is tested at 125% rated speed for five minutes, and a two plane full speed balance to 0.5 mils maximum is performed to limit vibration.

Stator Insulation Combinations

Insulation classes refer to the insulation’s ability to withstand heat for a specified period of time. This is due to the material each class consists of. Class H is temperature rated at 180°C (356°F), Class F at 155°C (311°F). Caterpillar uses Class H materials in the generator but only rate the generator at the conservative Class F temperature rise.

Windings are coated with various layers of insulation. Insulation materials currently in use (individually and in combinations) are acrylics, asphalts, epoxies, melamines, phenolics, polyamides, polyimides, polyesters, polyethylenes, and silicones. Some insulation uses are:

- Magnet wire with polyester and amide-imide overcoat
- Nomex™-mylar™-nomex™ ground insulation. (Mylar is a Du Pont polyester film.)

Shown are examples of system voltages that may be encountered. However, the list is by no means complete. In the US, system voltages are based on 120V with multiples of that voltage.

Nominal System Voltages*	Identical System Voltage
120	110, 115, 125
120 / 240	110 / 220, 115 / 230
208Y / 120	199Y / 115
240	220, 230
480	440, 460
500	550, 575
2400	2200, 2300, 2500
4160Y / 2400	3810, 4000

Figure 12.

System voltages are divided into classes to differentiate types of generators and the differences are illustrated below.

- **LOW VOLTAGE** — A class of nominal system voltages of 1 KV or less
- **MEDIUM VOLTAGE** — A class of nominal system voltages greater than 1 KV, but less than 100 KV
- **HIGH VOLTAGE** — A class of nominal system voltages equal to or greater than 100 KV and equal to or less than 230 KV

Generator armature windings must withstand a test voltage of 1000 volts plus two times the rated voltage of the machine. The field windings must withstand 1500 volts rms.

Megger readings of one meg-ohm per 1000 volts of generator rating are generally considered acceptable.

A **Megger test** is a process of measuring the insulation resistance with respect to ground. This figure is usually around 100 meg-ohms directly from the factory.

Larger generators are sometimes required to pass certain tests associated with insulation coordination for lightening and voltage surges. This requirement falls under basic impulse insulation levels (BIL), and must be tested for under surge conditions.

Shown below is a typical damage curve. Any generator operation with currents above this curve should be avoided. Although a generator may not necessarily fail suddenly when currents reach above the damage curve (like a fuse), currents above the damage curve will cause insulation to become brittle, carbonized, and cracked. Also, differential expansion of materials (e.g. Cu expands significantly and Fe expands very little) causes stress and stress cracking in insulation. Conductors may lose strength, fracture, and/or melt. However, insulation can safely exceed its rated temperature by 30° to 50°C if the overheating does not last too long.

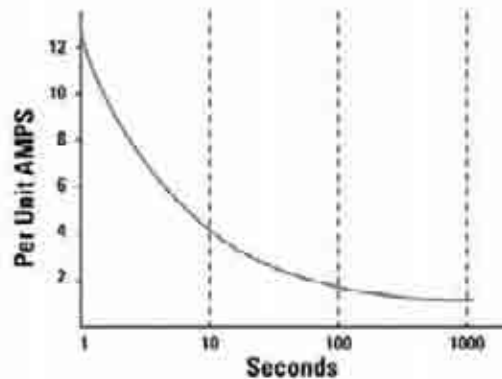

Figure 13.

Insulation Life

The more current the stator windings can accommodate, the greater the generator output. “Q” represents ampere conductors per inch of armature circumference. There are, however, limitations to ampere conductors per inch of armature circumference, temperature rise being the most important.

Temperature rise is the limitation of the insulation to withstand the heat produced when current runs through the stator windings. The thermal expansion of the wires from this heat plays a part in this limitation.

Since the late 1950’s, plastics have been used as the primary insulation for generators. As late as 1960, British standards specifications referred to insulation classes by material. Since the 1960’s, however, insulation classes have been referred to by the maximum temperature limit of the materials in each class. See the table provided.

Class	Max. Operating Temperature	Materials
A	105° C	Cotton, Silk, Paper, Suitably impregnated
B	130° C	Glass, Asbestos, Mica, Suitably bonded
F	155° C	Glass, asbestos, Mica, Bonded with materials that permit 155° C operation
H	180° C	Silicone Elastomer, Mica, Glass, Asbestos, Bonded with silicone resin

Insulation Classes

Figure 14.

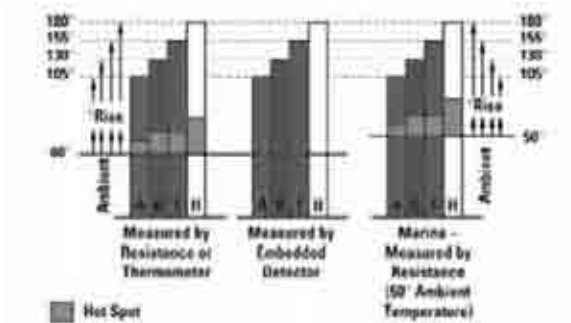

Figure 15.

The bar graphs provided show insulation class temperature limits measured by resistance or thermometer and by embedded detector. Notice the inclusion of the hot spot as a separate factor in the resistance graphs.

Ambient temperature and method of measurement further subdivide the maximum temperature limits shown in the table. Ambient temperature is usually considered to be 40°C (although marine and some others prefer 50°C). When measuring stator windings by resistance, a hot-spot allowance is added. The hot-spot is the spot in stator windings with the highest temperature. A hot-spot is located approximately in the center of each stator slot and approximately in the center of each field winding.

If an embedded detector (discussed later) measures the temperature limit of the stator windings, the hot-spot allowance is ignored.

This is because the embedded detector is located at the hot spot. Therefore, the measured temperature already includes the hot spot. Note that embedded detector can measure the temperature limit of the stator windings and is usually a standard factory test. Because the rotor is rotated, however, embedded detector cannot test the field windings, they must be tested by resistance.

There are two basic types of embedded detectors. **RTD's** (resistive temperature devices) are electronic sensing devices that vary resistance with a change in temperature. This change in resistance is then measured and converted into a temperature reading. They are the more fragile of the two devices discussed here and therefore are only used in form wound machines. RTD's deliver more of an average reading than the thermocouple. The **thermocouple** is a more robust type of temperature sensing device. It is used in a random wound machine due to this sturdier design. It delivers a reading at a precise point, usually the hot spot. Both devices can be placed in windings and also the machine's bearings. They can show increases in winding insulation temperature and prevent excess bearing heat effects. Both embedded detectors give allowances for hot spot temperatures based on the insulation type and the rating of the temperature.

Shown below are typical thermal endurance curve bands for the different insulation classes. Thermal endurance is the ability of the insulation to withstand heat. The curve bands predict insulation life in hours versus the temperature of the windings. There are many test points outside these bands; the points shown are merely representative. Note that this type of graph is used to compare insulation systems. These curve bands do not predict actual design life of a machine. For example, one CANNOT assume that the design life of a machine is "X" hours because the insulation life is "X" hours. The curve bands only COMPARE insulation systems.

Rule of thumb: For every 10°C increase in temperature, insulation life is halved.

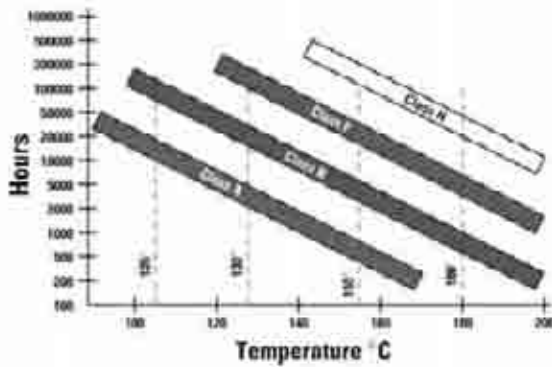

Figure 16.

There are several indications that thermal deterioration is occurring in winding insulation:

- Loss in weight and thickness
- Increase in stiffness or brittleness
- Increase in density
- Non-uniform shrinkage with cracks penetrating from the surface
- Reduced tensile strength
- Less resistance to moisture penetration
- Reduced dielectric strength
- Serious decrease in resistance

Insulation tends to breakdown at higher voltages due to the added emf force. SCR loads that are of high harmonic content can also seriously affect it.

Heat is not the only cause of winding insulation deterioration. Damage to insulation can occur during winding due to improper handling, careless winding, insufficient resin coverage, or insufficient cure time. Therefore, tests are conducted after every winding process is completed.

Additional causes of insulation failure are:

- Conducting contaminants like dirt, chemicals, etc.
- Mechanical damage from shock, vibration, foreign objects, stress, etc.

- Surge voltages generated in the load or the line
- Operation at abnormal voltage, current, or power factor
- Loosened coils and wedges
- Moisture on creepage surfaces
- Blocked ventilation passages
- Abrasives in the cooling air

Coil Connections

The design of the coil connections in a generator and the way a load is connected to a generator determine the level and type of output voltage from that generator.

Shown below are different types of connections for a single phase of a 4-pole, three-phase winding. The phase consists of four pole-phase groups — one for each pole in the phase. Each coil could have any number of turns, limited only by the space within the slot. The pole-phase groups can be connected in series, 4-parallel, or 2-series, 2-parallel.

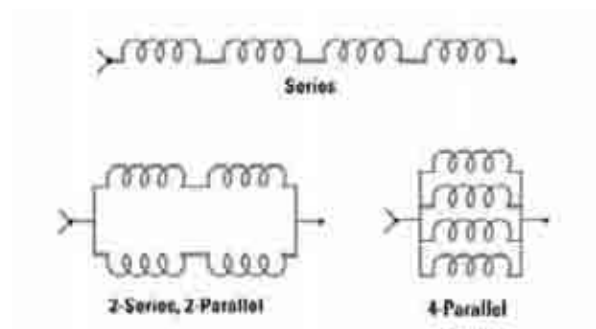

Figure 17.

Different types of connections induce different voltages. Therefore, the type of connections used in a generator depends on the voltage required by the load. Series connections produce high voltage and parallel connections produce low voltage. The series and series-parallel connections are often combined into the same generator so that the generator can be connected to produce either kind of voltage. This dual voltage capability is usually listed, for example, as “139/240-277/480V,” meaning the generator can be connected for either 139/240V or 277/480V. 139V and

277V are line-to-neutral voltages (single-phase), while 240V and 480V are line-to-line voltages (single-phase or three-phase).

All SR 4 Generators have 4, 6, 10, or 12 line leads or outputs. These can be connected into a low voltage Y configuration (coils parallel) or into a high voltage Y configuration (coils in series). Generators with 12 leads can be connected in delta configuration. Larger generators use more than one wire per line lead. This feature eases the problem of forming very heavy conductors inside a limited space for terminal connections.

All leads are identified. If more than one wire is used per line lead, a line lead number identifies each of these wires. Thus, on smaller generators, there would be only one wire marked T₁. However, on larger generators, there will be two or more wires marked T₁. These are to be connected together to form one lead.

The first voltage listed in a rating like 220/440 volts is the line-to-line voltage at the specified frequency when the generator leads are connected for the low voltage. The second voltage listed is the line-to-line voltage at the specified frequency when the re-connectable line leads are series connected for high voltage.

Some applications demand a **wye** connection rather than a **delta** connection and vice-versa. For example, the delta connection is sometimes used to obtain single-phase 120-240 volts, 3-wire, along with three-phase, 3-wire on the same generator. Shown below is a wye and delta connection.

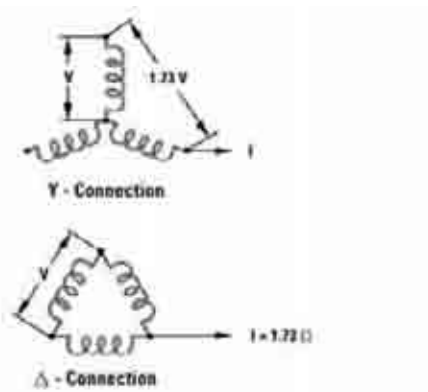

Figure 18.

In a wye connection, the terminal voltage is 1.73 times the terminal-to-neutral voltage (represented by the letter “V” in the drawing). In the same generator, a delta connection would have the same terminal-to-neutral voltage as the wye connection for its terminal voltage. However, the delta line current (I) would now be 1.73 times the wye line current (I).

A wye connection can be structured in either of the two ways shown: fixed neutral connection or broken neutral connection. The broken neutral allows you to reconfigure from a wye to delta and vice-versa. It also provides differential protection by allowing the machine to monitor the currents into and out of individual phases.

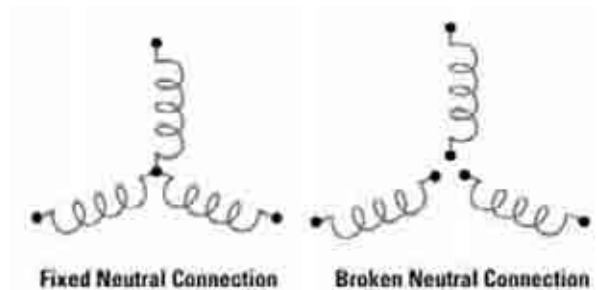

Figure 19.

The zigzag connection is sometimes used to get an alternative voltage from a generator. For example, the connection shown can give 120-208V from a generator wound for 120-240V.



Figure 20.

Several single-phase connections are possible for 2-wire or 3-wire loads. These connections

are normally used only on smaller generators at or below 250 kW. An **open delta** is reconfigured from an original delta from three-phase to single-phase use. But, this type of connection will only give you around 57% of the original three-phase rating.

The lead terminal numbering system follows the pattern shown. This system is used for both three-phase generators and motors.

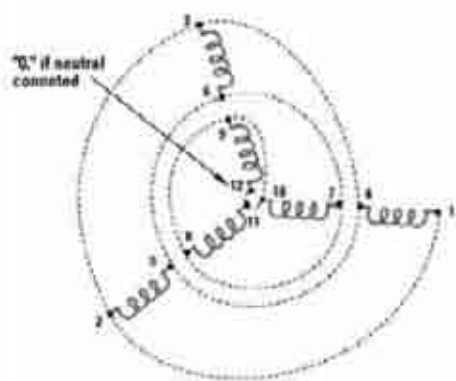

Figure 21.

Generator Features and Attachments

Several attachments and features can also be configured to assist in meeting generator requirements. These can include bearings, environmental protection devices and space heaters.

Bearings are devices that permit smooth movement between surfaces. In a generator, they are used to hold the rotor in place and allow that smooth rotation.

A Single Bearing system is used in the smaller generators with lighter weight rotors. It is necessary to have a two bearing system when the weight of the rotor exceeds the limits of the engine rear main bearing. In a traditional two bearing system, the generator is not attached directly to the engine's flywheel housing. This brings about alignment difficulty due to the separation of the two machines. A close coupled two bearing system alleviates these original alignment problems by attaching the generator to the flywheel housing.

Space Heaters are electrical resistance heaters that are often used to help prevent condensation and moisture absorption during nonuse periods. They are application specific and their operation time can vary due to this application.

IP Protection Refers to the degree of protection an enclosure provides for a rotating machine. This is protection both for persons in contact with moving parts and for the protection of machines against the harmful effects due to the collection of water and dust. **TEWAC & TEAC** are totally enclosed water cooled and totally enclosed air cooled respectively.

Physical Data

Rotor weight indicates the total weight of the generator rotor. When used with the formula for inertia, the flywheel effect of the generator can be found. Engineers may use these figures when generator loads are sudden or cyclic.

Stator Weight is given in kilograms and pounds and gives an indication of the capacity of a generator. Engineers generally assume that a heavier stator contains more working copper and iron and therefore has greater capabilities.

Inertia data is essential to studies of transient response, such as the effect of a larger generator with more rotor weight and greater mass moment of inertia. When the information is given to an engineer, it must be correctly identified.

These figures list the mass moment of inertia in System International units and English units. Other symbols used to designate inertia of rotating machinery are WK^2 , WR^2 , and GD^2 . The standard inertia presentation below is recognized anywhere in the world and can be readily converted to other inertia designations.

$N \bullet m \text{ sec}^2 =$	$\frac{\text{Force}}{\text{Newton}}$	\times	$\frac{\text{Distance}}{\text{meter}}$	\times	$\frac{\text{Time}^2}{\text{Second}^2}$
$lb \bullet in. \text{ sec}^2 =$	lb	\times	$in.$	\times	Second^2

To convert to moment of inertia (WK^2) in SI units, multiply $N \cdot m \cdot sec^2$ by 9.803 m/sec^2 . Multiply $lb \cdot in. \cdot sec^2$ by 2.683 to get inertia (WK^2) in $lb \cdot ft^2$, the common English unit designation.

Center of gravity is information that gives the location of the generator center of weight in three planes. With the total generator weight, the information can be used to determine the center of gravity of an assembly consisting of engine, generator, radiator, and base. Combined calculations require reducing all values to moments ($lb \cdot in.$ or $kg \cdot mm$). These are summed algebraically in each plane of reference.

The **nameplate** is exactly what its name implies. It is an engraved metal plate or printed film on the side of a motor/generator with a minimum required amount of information needed to identify its functionality.

The following is the required information as set by **NEMA** (National Electrical Manufacturers Association):

- a. Manufacturer's type and frame designation
- b. Kilovolt-ampere output
- c. Power factor
- d. Time rating
- e. Temperature rise*
- f. Rated speed in rpm
- g. Voltage
- h. Rated current in amperes per terminal
- i. Number of phases
- j. Frequency
- k. Rated field current**
- l. Rated excitation voltage

Additional information may be included such as:

- m. Enclosure or IP code
- n. Manufacturers name, mark, or logo
- o. Manufacturer's plant location
- p. Serial number or date of manufacture.

*As an alternate marking, this item shall be permitted to be replaced by the following:

- a. Maximum ambient temperature for which the generator is designed
- b. Insulation system designation (if the armature and field use different classes of insulation systems, both shall be given, that for the armature being given first)

** Applies to the exciter in the case of a brush-less machine

Generating sets shall bear the following rating plates as set by **ISO 8528** (International Standards Organization):

The nameplate for the set shall give at least the following information:

- 1) the words "Generating set ISO 8528"
- 2) the manufacturer's name or mark
- 3) the serial number of the set
- 4) the year of manufacture of the set
- 5) the rated power, in kilowatts, with the prefixes COP, PRP or LTP, in accordance with ISO 8528-1:1993, clause 13
- 6) the performance class in accordance with ISO 8528-1:1993, clause 7
- 7) the rated power factor
- 8) the maximum site altitude above sea-level, in meters
- 9) the maximum ambient temperature, in degrees Celsius
- 10) the rated frequency, in hertz
- 11) the rated voltage, in volts
- 12) the rated current, in amperes
- 13) the mass, in kilograms.

The rating and class of output of the generator shall be combined as follows:

- a) Where a continuous rating based on duty type S1 is stated, the rated output shall be followed by the marking "BR" (basic continuous rating), e.g. Sr=22 kVA BR;
- b) Where a rating with discrete constant loads based on duty type S10 is stated, the basic continuous rating based on S1 shall be marked as in a). In addition the peak rated output shall be shown followed by the marking "PR" (peak continuous rating), the maximum running time of 500 h per year and the factor T_L , e.g. Sr=24 kVA PR 500 h per year, $T_L=0,9$.

NEMA & IEC Design Considerations

The following are design considerations as set in the NEMA code book.

Temperature Rise

The observable temperature rise under rated load conditions of each of the various parts

of the synchronous generator, above the temperature of the cooling air, shall not exceed the values in the table below. The temperature of the cooling air is the temperature of the external air as it enters the ventilating openings of the machine, and the temperature rises given in the table are based on a maximum temperature of 40°C. for this external air.

TEMPERATURE RISE

Item	Machine Part	Method of Temperature Determination	Temperature Rise, Degrees C°			
			Class of Insulation System			
			A	B	F	H
a.	Armature windings					
	1. All kVA ratings	Resistance	60	80	105	125
	2. 1563 kVA and less	Embedded detector**	70	90	115	140
	3. Over 1563 kVA					
	a) 7000 volts and less	Embedded detector**	65	85	110	135
	b) Over 7000 volts	Embedded detector**	60	80	105	125
b.	Field winding	Resistance	60	80	105	125
c.	The temperature attained by cores, amortisseur windings, collector rings, and miscellaneous parts (such as brushholders, brushes, pole tips, etc.) shall not injure the insulation or the machine in any respect.					

*For machines which operate under prevailing barometric pressure and which are designed not to exceed the specified temperature rise at altitudes from 3300 feet (1000 meters) to 13000 feet (4000 meters), the temperature rises, as checked by tests at low altitudes, shall be less than those listed in the foregoing table by 1 percent of the specified temperature rise for each 330 feet (100 meters) of altitude in excess of 3300 feet (1000 meters).

**Embedded detectors are located within the slot of the machine and can be either resistance elements or thermocouples. For machines equipped with embedded detectors, this method shall be used to demonstrate conformity with the standard (see 20.63).

NOTES

1—Temperature rises in the above table are based upon generators rated on a continuous duty basis. Synchronous generators may be rated on a stand-by duty basis (see 22.85). In such cases, it is recommended that temperature rises not exceed those in the foregoing table by more than 25°C under continuous operation at a stand-by rating.

2—Diesel engine specifications often call for machines which are suitable for 10-percent overload for 2 hours out of any 24 consecutive hours of operation. Generators having a corresponding overload capability are sometimes required. In such cases, it is recommended that the generators and their excitation systems be designed to deliver 110 percent of kVA at rated power factor, frequency, and voltage with temperature rises under rated load conditions not exceeding those given in the above table.

3—Temperature rises in the foregoing table are based upon a reference ambient temperature of 40°C. However, it is recognized that synchronous generators may be required to operate at an ambient temperature higher than 40°C. The temperature rises of the generators given in the foregoing table shall be reduced by the number of degrees that the ambient temperature exceeds 40°C.

(Exception—for totally enclosed water-air-cooled machines, the temperature of the cooling air is the temperature of the air leaving the coolers. Totally enclosed water-air-cooled machines are normally designed for the maximum cooling water temperature encountered at the location where each machine is to be installed. With a cooling water temperature not exceeding that for which the machine is designed.

a. On machines designed for cooling water temperatures from 5°C to 30°C — the temperature of the air leaving the coolers shall not exceed 40°C.

b. On machines designed for higher cooling water temperatures — the temperature of the air leaving the coolers shall be permitted to exceed 40°C provided the temperature rises of the machine parts are then limited to values less than those given in the table by the number of degrees that the temperature of the air leaving the coolers exceeds 40°C.)

Table 2.

Maximum Momentary Overloads

Synchronous Generators shall be capable of carrying a 1-minute overload with the field set for normal rated load excitation in accordance with the following.

Synchronous Speed, RPM	Armature Current, Percent of Normal Rated Current
1801 and over	130
1800 and below	150

Table 3.

It is recognized that the voltage and power factor will differ from the rated load values when generators are subjected to this overload condition. Also, since the heating affect in the machine winding varies approximately as the product of the square of the current and the time for which this current is being carried, the overload condition will result in increased temperatures and a reduction in insulation life. The generator shall therefore not be subjected to this extreme condition for more than a few times in it's life. It is assumed that this excess capacity is required only to coordinate the generator with the control and protective devices.

Maximum Deviation Factor

The deviation factor of the open circuit line-to-line terminal voltage of synchronous generators shall not exceed 0.1.

(TIF)

TIF, Telephone Influence Factor, shall be measured at the generator terminals on open circuit at rated voltage and frequency. When specified, the balance TIF is based on the following weighting Factors;

TIF according to the 1960 Single frequency weighting

Frequency	TIF	Frequency	TIF
60	0.5	1860	7820
180	30	1980	8330
300	225	2100	8830
360	400	2160	9080
420	650	2220	9330
540	1320	2340	9840
660	2260	2460	10340
720	2760	2580	10600
780	3360	2820	10210
900	4350	2940	9820
1000	5000	3000	9670
1020	5100	3180	8740
1080	5400	3300	8090
1140	5630	3540	6730
1260	6050	3660	6130
1380	6370	3900	4400
1440	6650	4020	3700
1500	6680	4260	2750
1620	6970	4380	2190
1740	7320	5000	840
1800	7570		

Table 4.

Shall not exceed the following values;

kVA Rating of generator	TIF
125 to 4999	150
5000 to 19999	75
2000 and above	70

Table 5.

When specified, the residual component TIF based on the weighting factors given shall not exceed the following values. These residual components apply to those voltage ratings 2000 volts or higher.

kVA Rating of generator	TIF (residual)
125 to 4999	150
5000 to 19999	75
2000 and above	70

Table 6.

Short Circuit Requirements

A synchronous generator shall be capable of withstanding, without injury, a 30 second, three-phase short circuit when operating at rated kVA and power factor, at five percent over voltage, with fixed excitation. The generator shall also be capable of withstanding, without injury, any other short circuit at it's terminals of 30 seconds or less provided:

- a. The machine phase currents under fault conditions are such that the negative Phase sequence current, (I_2), expressed in per unit of stator current at rated kVA, and the duration of the fault in seconds, t, are limited to values which give an integrated product, equal or less than:
 1. 40 for salient pole machines
 2. 30 for air cooled cylindrical rotor machines
- b. The maximum phase current is limited by external means to a value which does not exceed the maximum phase current obtained from the three-phase fault.

Overspeed

Synchronous generator shall be so constructed that, in an emergency not to exceed two minutes, they will withstand without mechanical injury overspeed's above synchronous speed in accordance with the following.

Synchronous Speed, RPM	Overspeed, Percent of Synchronous Speed
1801 and over	20
1800 and below	25

Table 7.

Generator Performance Characteristics

Rated and Per Unit

Per unit is a decimal fraction of some whole value. "Twenty percent" (20%) indicates part of some whole value but could also be written as 0.20. "Per unit" is a *pure number*. It has **no** label such as volts, amperes, or Ohms.

The per-unit system offers benefits like eliminating many of the $\sqrt{3}$'s inherent in three-phase calculations. Also on a per-unit basis, all generators, transmission lines, motors, etc., look more or less alike.

KVA, volts, amps, power factor, resistance and reactance are all figures converted to per-unit values. Per-unit calculations are defined as the actual value of the figure divided by the base value. It is customary to select voltage and apparent power base values, once these are done, all other base values can be calculated. (see reactance for more per unit calculations)

To convert a circuit quantity to per unit, divide by the base value, which is usually the rated value. For example, if you have a 240/120-V, 120 kVA generator that is operated at 100 kVA with 220 volts, the per unit values are as shown:

$$V_{pu} = \frac{220}{240} = 0.917 \quad S_{pu} = \frac{100}{120} = 0.833$$

And from these base numbers you can calculate current and impedance bases:

$$I_{base} = \frac{S_{base}}{V_{base}} = \frac{12 \text{ kVA}}{240 \text{ V}} = 50 \text{ A} \quad Z_{base} = \frac{V_{base}^2}{S_{base}} = \frac{(240 \text{ V})^2}{12 \text{ kVA}} = 4.8 \Omega$$

Efficiency

Efficiency is the percentage of engine flywheel horsepower that is converted into electrical output, or in other words, power out of the generator divided by power in. 100% efficiency is a theoretical level that assumes no losses in heat, windage, or friction. Generator efficiencies are published at 100% of rated. Caterpillar generators are designed for

highest efficiency in the prime power load range that is typically 75% of rated.

Percent generator efficiency is kVA times power factor times 100 all divided by kVA times power factor plus generator losses plus exciter losses.

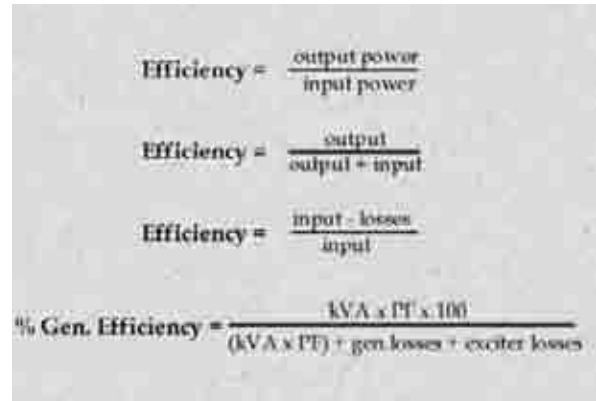

$$\text{Efficiency} = \frac{\text{output power}}{\text{input power}}$$

$$\text{Efficiency} = \frac{\text{output}}{\text{output} + \text{input}}$$

$$\text{Efficiency} = \frac{\text{input} - \text{losses}}{\text{input}}$$

$$\% \text{ Gen. Efficiency} = \frac{\text{kVA} \times \text{PF} \times 100}{(\text{kVA} \times \text{PF}) + \text{gen losses} + \text{exciter losses}}$$

Figure 22.

To consider the efficiency of a generator, its losses must be considered.

- **ARMATURE WINDING** — The loss based upon phase currents and phase resistances.
- **FIELD** — The loss due to field current and field resistance.
- **CORE LOSS** — Iron losses, hysteresis, and eddy currents due to the flux variation in the armature core.
- **STRAY LOAD LOSSES** — Iron losses and eddy current losses in the copper due to fluxes varying with load and saturation.
- **FRICITION AND WINDAGE LOSS** — Loss of the power used to overcome bearing friction and windage. There is a power used against the friction between the bearings and the rotor that creates a friction loss. The power necessary to move the rotor poles through the air and to drive cooling air through the generator creates windage loss.
- **EXCITER LOSS** — core losses, friction and windage losses, etc. are all included in the exciter loss, just as in the main generator.

Fault Current/Short Circuits

Short circuits generally occur when electric current is diverted from its intended path to ground or another line of the generator. When short circuits occur, it is necessary for a generator to provide adequate fault current to the short in order to give a protective device (breakers and fuses) enough time to react. PM (permanent magnet) generators do not have a problem with this due to their excitation characteristics while an SE (self excited) generator may have trouble providing this current for enough cycles. (See the section entitled “NEMA design considerations” for there official standards on short circuits.)

When a generator experiences a sudden load increase (e.g. starting a motor), output voltage and speed of the genset dip for a short time. This is called a **transient dip** (shown below). When the load is thrown off, an overshoot occurs. Without proper generator design, this overshoot could potentially cause a short-circuit.

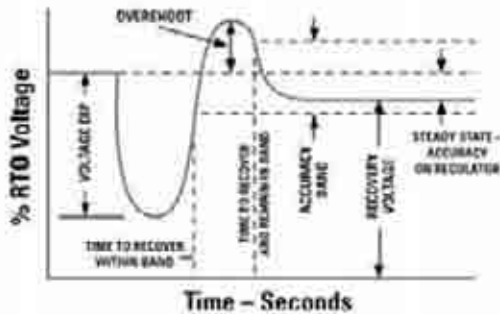

Figure 23.

Each phase of a generator has the following impedances: equivalent armature reactance, armature leakage reactance, armature resistance, synchronous reactance, synchronous impedance, voltage proportional to excitation requirements, line current, and phase voltage.

The vectors shown demonstrate that to maintain constant voltage at the terminals, the excitation requirements will vary according to the power factor. Hence, excitation requirements are greatest at

lagging power factors and less at leading power factors.

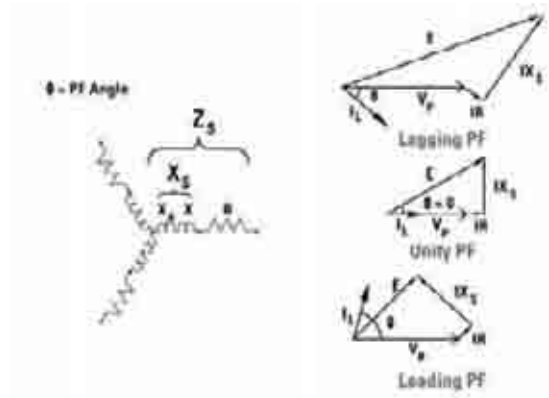
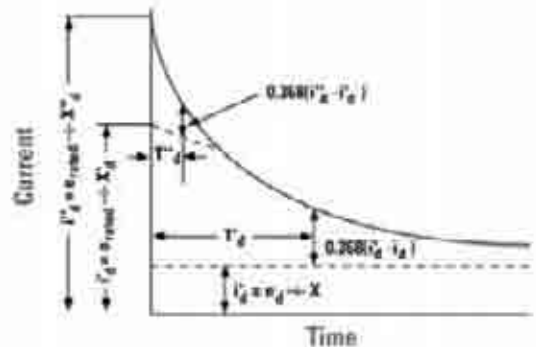

Figure 24.

There may also be a direct current component to short circuits. In most short circuits, the ratio of reactance to resistance is high. If a fault occurs at zero voltage on the sine wave in such a circuit, the current will not be symmetrical. It will contain a DC component that will offset the short circuit current for a very short time.

A three-phase fault is just what it says, a short between all three phases of the output. Likewise, a line-to-line fault is a short between two of the three phases, and the same concept goes for line-to-neutral and line-to-ground faults. A more detailed explanation of faults is covered under “Power Systems.”

See the illustration provided for a demonstration of short circuit.



Symmetrical Component of 3-Phase Short Circuit

Figure 25.

Stator resistance refers to the internal resistance of the generator that is developed by the stator metal and configuration.

Assume each coil represents an equal resistance value in ohms. The numbers shown represent the line and neutral in the stator windings. The following diagrams show the points at which the listed resistance value or a multiple of it applies:

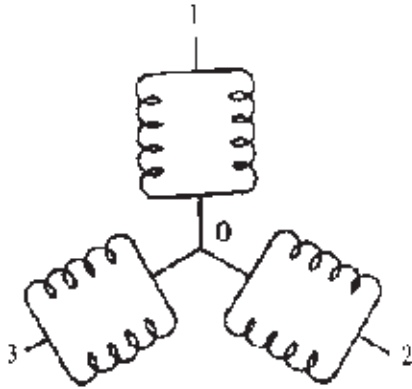

Figure 26.

- For resistance of 1-2, 2-3, or 3-1 (line-to-line), single coil resistance value applies.
 - * Note that the generator coils are connected in parallel for low voltage.
- For resistance of 1-0, 2-0, or 3-0 (line-to-neutral), divide the coil resistance by 2.

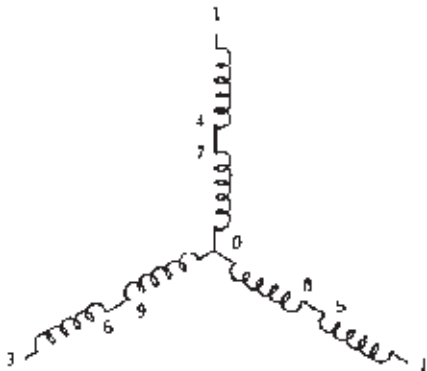

Figure 27.

In this case where the generator coils are connected in series for high voltage:

- For resistance of 1-2, 2-3, 3-1 (line-to-line), multiply the coil resistance by 4.

- For resistance of 1-4, 2-5, 3-6, 7-0, 8-0, 9-0 (individual coil resistance), single coil resistance applies
- For resistance of 1-0, 2-0, and 3-0, multiply the coil resistance by 2.

Resistance measurements will be valid only if made with instruments capable of measuring very low resistance. Do not attempt to use an Ohmmeter. The inaccuracy is too great to have any value.

Resistance values vary with temperature. Given resistance values apply only at 25°C (77°F). Correction must be applied at other temperatures. For temperatures other than 25°C, multiply the listed value by 0.00393 and by the total temperature difference between 25°C and the existing temperature. Add the result to the listed value if the temperature is higher. Subtract the result if the temperature is lower.

A reverse process can find internal temperature of generator coils. The generator stator resistance must be accurately measured.

The **open circuit time constant** is determined from a test performed as follows:

The generator is operating at normal rated voltage with no load. The main rotating field is supplied from a separate source, usually a battery. The rotating field input is short-circuited and the voltage across the generator output terminals will reduce. Time, in seconds, for the generator terminal voltage to reach 36.8% of its original value is recorded as the open circuit time constant. The figure is primarily used in the design of voltage regulators. Some engineers use the open circuit time constant along with another factor called generator time constant, which can be supplied upon request. Individually and together, these two time constants provide switchgear and distribution designers with information needed to study the possible voltage changes resulting from severe load changes.

The **generator time constant** is a measure of the magnetic inertia in a generator and gives an indication of machine performance under short circuit conditions. The factor is determined by actual running tests where the generator output is short-circuited and the reaction is recorded. The time elapsed between short circuit application and voltage decline to 36.8% of normal is the generator time constant. The symbol is TD-SC and it has a value in seconds approximately equal to 10% of the open circuit time constant.

The **short circuit ratio** gives an indication of generator response to a suddenly applied load. It is the ratio of the field current required for the rated voltage at open circuit to the field current required for the rated armature current at short circuit. It can also be found as the reciprocal of the synchronous reactance. This number is usually on the order of 0.5-0.6.

Reactance

The **impedance**, or combined reactance and resistance control the flow of current in an alternating current circuit. In generator sets, the generator reactance is such a large part of the total impedance that the resistance can be disregarded. The amount of current that will flow as a result of a ground or short circuit is therefore determined by the various generator reactances (assuming a constant field current). The five major reactances are as follows.

Table of Generator Reactances				
Name	Sym	Range	Importance	Appr. time effective
Sub-transient reactance	X''d	.08 to .26	Determines max. inst. current	1 to 6 cycles
Transient reactance	X'd	.16 to .45	Determines current when breaker opens	3 cycles to 2 sec.
Synchronous reactance	Xd	2.0 to 3.9	Determines steady state current	continuous after 2 sec.
Zero sequence reactance	Xo	.02 to .25	To determine fault current in grounded neutral machines	
Negative phase sequence reactance	X2	.1 to .4	To determine current in line-to-line faults	

Table 8.

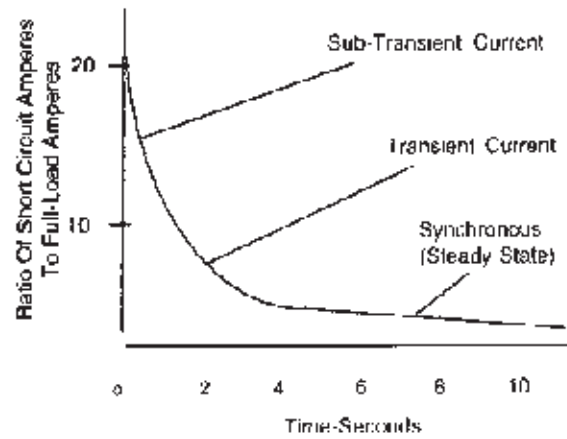

Figure 28.

Synchronous reactance determines steady-state current. However, when a sudden change from steady-state occurs, such as short circuit, other reactances come into play. This happens because the flux in the machine cannot change immediately.

- Sub-transient reactance determines maximum instantaneous current. It lasts up to about 6 cycles.
- Transient reactance is a longer lasting reactance determining current up to as much as 5 seconds.

Other reactances not subject to time limitations:

- Zero sequence reactance determines neutral currents in grounding studies. It is also a factor in determining neutral currents when third harmonics are encountered.
- Negative phase sequence reactance is used in calculating line-to-line faults.

The factors involved in a short circuit are defined in the illustration provided.

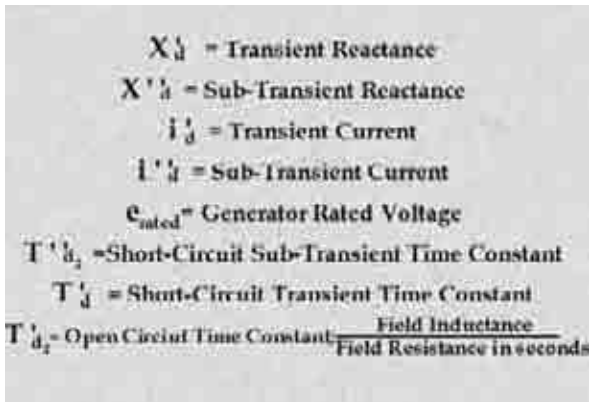

Figure 29.

Transient Reactance (X'd)

The term “transient reactance” is usually expressed by the symbol X'd. It is one of the five reactance figures frequently used by engineers when comparing generator capability with load requirement, or when comparing one generator with another. Reactance figures are always used with the related kVA rating (called Base kVA), the refuted ampere rating (called Base Amperes), and the related voltage (called Base Voltage). The listed figures are “per unit” values (abbreviated, P.U. or p.u.). “Per unit” is a decimal fraction of some whole value. “Twenty percent” (20%) indicates part of some whole value but could also be written as 0.20. “Per unit” is a pure number. It has no label such as volts, amperes, or Ohms. Reactance are also expressed in percent (100% × per unit).

Transient Reactance Note: This expression will be used to explain reactance values in general and to show some of the related arithmetic and uses of the five listed reactance values.

The transient reactance is similar to sub-transient reactance, except that transient reactance determines the amount of current for approximately three cycles to two seconds.

The five listed reactance per unit values describe the line-to-neutral value at the kVA and ampere condition (or volt condition) listed in the same price list reference number and

rating. These line-to-neutral reactance per unit values can be directly converted to a line-to-neutral ohmic value by use Ohm’s law and the per unit value: divide the line-to-neutral rated voltage by the rated line amperes. The result will be Ohms. Multiply the result by the per unit value. The result is Ohms reactance.

Example: Transient reactance = 0.2490 per unit. The base voltage is 480, base ampere is 263. Generator voltage listed is line-to-line. This must be converted to line-to-neutral voltage: 480 divided by the 43 equals 277 volts, which is the “base voltage”.

$$\text{Transient Reactance, ohms} = \frac{277}{263} \times 0.2490 = 0.262 \text{ Ohms}$$

Most engineers prefer a presentation in the following order: line-to-line voltage, prime power kVA, line amperes (at the listed line-to-line voltage), and the line-to-neutral reactance in the per unit value.

Various ratings on a specific generator do not change the reactance. However, the per unit value reactance do change directly with the rating. Example: Determine the per unit value of transient reactance of a generator at a 180 base kVA at 480 volts. At 219 kVA, 480 volts, the reactance is 0.2490 P.U. Per unit values change directly with the base kVA.

$$\frac{180}{219} \times 0.2490 = 0.2046 \text{ per unit}$$

The reactance in ohms has not changed because at 180 kVA, the line ampere rating would be 216 amperes. The calculation shows:

$$\frac{277 \text{ volts}}{216 \text{ amperes}} \times 0.2046 = 0.262 \text{ Ohms}$$

Per unit reactance changes inversely (volts down, reactance up) with the square of the voltage ratio if the kVA rating remains the same. Example: At 480 volts the listed transient reactance is 0.2490. The base voltage is to be decreased from 480 volts to 416 volts. The kVA is to remain the same. The per unit transient reactance at the lower voltage is:

$$(480/416)^2 \times 0.2490 = 0.3310 \text{ per unit}$$

The ohmic line-to-neutral transient reactance has not changed. Line-to-neutral voltage is now:

$$\frac{416}{\sqrt{3}} = 240 \text{ volts}$$

Since the kVA rating is to remain at 219 kVA, the line ampere rating is:

$$\frac{219 \text{ kVA} \times 1000}{\sqrt{3} \times 416} = 303$$

Transient reactance in ohms is:

$$\frac{240 \text{ volts} \times 0.3310}{303 \text{ amperes}} = 0.262 \text{ Ohms}$$

Other terms relating to reactance:

Direct — All of the figures quoted in the Caterpillars TMI system are “direct axis” reactance per unit values. This data can also be shown in quadrature axis figures.

Saturated — Where applicable, figures are calculated at magnetic saturation. Occasionally an unsaturated value of a reactance may be required.

Transient reactance (per unit) figures are used to approximate the current at the time a circuit breaker opens under three-phase, short-circuit conditions. A circuit breaker will probably open at 7 cycles (0.13 seconds at 60 Hz), which is within the time transient reactance values apply (about 6 cycles to 5 seconds). The calculation requires two values — base amperes and the transient reactance. For a generator at 60 Hz, 480 volts, divide the base amperes by the transient reactance per unit value:

Example: Generator base amps = 263A

Transient reactance = 0.2490

$$\frac{263 \text{ amperes}}{0.2490} = 1056 \text{ amperes}$$

Sub-Transient Reactance (X”d)

If a generator is operating at normal voltage and a short circuit occurs a large amount of current will flow. The initial value (for approximately the first six cycles), in terms of full load current, is expressed by voltage divided by subtransient reactance.

This term is usually expressed as X”d and for SR 4 Generators has a per unit (P. U.) value of 0.1 to 0.3. Engineers frequently request the percent subtransient reactance. Per unit values are directly convertible to percent: 0.1 becomes 10%, 0.3 becomes 30%. Engineers also request the subtransient impedance. This implies the Ohmic line-to-neutral reactance since the stator resistance is less than 2% of the line-to-neutral impedance. Calculate the subtransient line-to-neutral reactance as:

$$\frac{\text{volts, line-neutral}}{\text{base amperes}} \times X”d$$

For a generator at 60 Hz, 219 kVA, with X”d = 0.120 and base amperes of 263:

$$\frac{480 \text{ volts}}{\sqrt{3}} = 277 \text{ volts, line-neutral}$$

$$\frac{277}{263 \text{ amperes}} \times 0.1201 = 0.1265 \text{ Ohm}$$

The subtransient reactance applies to a time period ranging from zero to five cycles. The per unit value is often used to determine the maximum current in event of a short circuit. The RMS* symmetrical current will be the rated amperes divided by the subtransient reactance per unit value. Under three-phase short circuit, this generator can produce:

$$\frac{263}{0.1201} = 2190 \text{ amperes RMS}$$

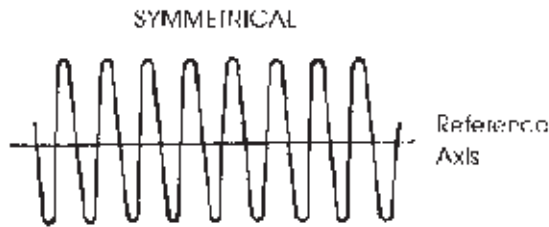

Figure 30.

Asymmetrical refers to a current that is not centered, or symmetrical, to a fixed reference axis.

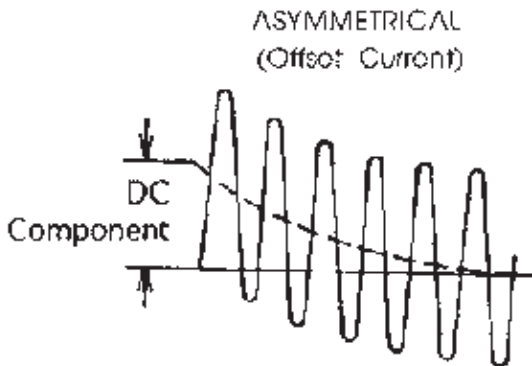

Figure 31.

The point in time at which the short circuit occurs determines if the resultant current is initially symmetrical or asymmetrical or a combination of each. If the fault occurred the instant the voltage is crossing the zero line, the current will be asymmetrical. The resulting value is known as maximum asymmetrical current. If the fault occurred when the voltage is at a positive or negative peak, the resultant current will be symmetrical. A fault occurring at any point in time between zero crossing, and the positive or negative peak will produce a lesser value of asymmetrical current.

In time — within one to five cycles — the asymmetrical current declines to a very low value. From that time forward, the symmetrical current is the only significant current.

- RMS means root mean square and is the value indicated by the more common electric measuring equipment — ammeters, voltmeters. Symmetrical refers to a current that remains centered about a fixed reference axis.

The asymmetrical current is also known as the “DC (direct current) component”.

The maximum asymmetrical short circuit RMS current can be found by multiplying the RMS symmetrical value by 1.732 (square root of 3). In the above example, the generator will produce $2190 \times \sqrt{3} = 3793$ RMS amperes, asymmetrical.

Calculations involving circuit breakers normally require peak currents. Symmetrical and asymmetrical currents from an SR 4 Generator can be converted to peak values by multiplying either value by the square root of 2 (1.414). In the above example, the generator will produce:

$$2190 \times \sqrt{2} = 3096 \text{ peak symmetrical amperes}$$

or

$$3793 \times \sqrt{2} = 5363 \text{ peak asymmetrical amperes}$$

Note that a smaller subtransient reactance per unit value results in higher available short-circuit current. Available short-circuit current is sometimes expressed as a multiplier (called available current ratio), which is the reciprocal of the per unit subtransient reactance. For this generator,

$$1 \div 0.1201 = 8.326.$$

Rated current times that multiplier equals RMS symmetrical current:

$$263 \text{ Amperes} \times 8.326 = 2190$$

Per unit subtransient reactance values of SR 4 Generators are about one-half the transient reactance per unit value.

Some engineers also use Sub-Transient reactance to determine the approximate voltage dip on a generator when starting large motors.

Synchronous Reactance (Xd)

After transient conditions have occurred, current flow is determined by the synchronous reactance. This is a steady state value and is effective after approximately two seconds.

This term is identified by the symbol X_d and has a per unit value of 2.0 to 4 in. SR 4 Generators. This factor is used to determine the steady-state fault current capability of a separately excited generator. (The short-circuit current which would be produced after five seconds.) Self-excited generators, such as the SR 4, lose excitation before five seconds. Hence, the synchronous reactance factor cannot be used to determine the actual steady-state fault current. The factor does, however, give a comparison with other generators by considering the probable performance if excited from a separate source.

The following diagram indicates the current available at various periods of time:

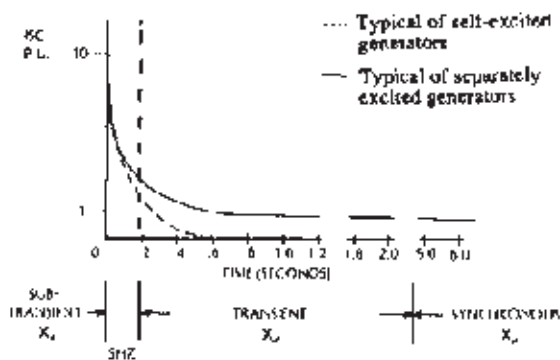

Figure 32.

Negative Sequence Reactance (X2)

The negative sequence reactance is an important factor in determining the fault current on a line-to-line short circuit in a three-phase unit.

This factor has a symbol X_2 and a per unit value that approximates the value of the subtransient per unit reactance value. Engineers use this figure when calculating probable fault currents in event of a line-to-line short circuit from a particular generator.

Calculation is very similar to that used for subtransient short circuits. For a generator at 60 Hz, 219 kVA, 263 amperes, and X_2 of 0.1543:

$$\text{amperes, RMS}_{SC} = \frac{\text{rated amperes} \times \sqrt{3}}{X''_d + X_2}$$

$$\frac{263 \times \sqrt{3}}{0.1201 + 0.1543} = \frac{263 \times \sqrt{3}}{0.2744}$$

= 1660 amperes, the RMS effective symmetrical current. The peak symmetrical value is found by multiplying the above result by $\sqrt{2}$
 $1660 \times 1.414 = 2347$ amperes

RMS asymmetrical value is determined from:
 $\text{RMS} \times \sqrt{3} = 1660 \times 1.732 = 2875$

The peak asymmetrical value is the RMS asymmetrical value multiplied by 1.414, which equals 4065 amperes.

Zero Sequence Reactance (X0)

The zero sequence reactance is the major factor determining the ground current in case of a grounded neutral unit having a phase-to-ground fault.

This reactance factor has the symbol X_0 and a per unit value of 0.03 to 0.13 or approximately one-third the value of the subtransient per unit reactance figure. The factor is used to determine probable value of line-to-neutral, short-circuit currents and possible line-to-ground currents in the event the neutral is grounded and a line-to-ground fault occurs. Fault current calculation is similar to those of line-to-line calculation:

$$\text{amperes, RMS} = \frac{\text{rated amperes} \times 3}{X''_d + X_2 + X_0}$$

For a generator at 60 Hz, 219 kVA, 263 amperes and X_0 of 0.0450:

$$\frac{263 \times 3}{0.1201 + 0.1543 + 0.0450} = \frac{263 \times 3}{0.3194}$$

= 2470 amperes, RMS, symmetrical

The peak value can be found by multiplying the RMS value by $\sqrt{2}$:
 $2470 \times \sqrt{2} = 3493$ amperes, peak, symmetrical

RMS asymmetrical value can be found by multiplying the RMS symmetrical value by $\sqrt{3}$.

Note: Available currents resulting from different type of faults are different. The line-to-neutral short circuit is often the highest value and the most likely to occur.

Harmonics & Distortion

Quality of electrical performance is a measure of how close the electrical output of the generator is to a true sine wave. The ideal voltage waveform is a sine wave pattern in which a voltage cycle starts at zero, increases to a positive peak, returns to zero, increases to a negative peak, and finally returns to zero, completing the cycle.

The actual voltage waveform from rotating machinery is never perfect. Internal generator and external load characteristics cause distortions in the wave. These factors impair the consistency of the generator output, and can result in voltage regulator sensing errors and incorrect instrument readings.

In brief, **harmonics** are energy levels existing at multiples of the fundamental wave's frequency. Harmonics produce undesirable effects in the generator, but motors also suffer from excessive harmonics. The remainder of this discussion will be limited to harmonics of lower orders, those with significant magnitudes, are the 3rd, 5th, and 7th. Generators are symmetrical machines that have even numbers of north and south poles, resulting in cancellation of all even number harmonics. Only odd number harmonics remain. In a 60 Hz set, the third harmonic occurs at 180 Hz, the 5th at 300 Hz, 7th at 420 Hz, and so on. The effects of 3rd and 5th harmonics on the composite waveform are illustrated:

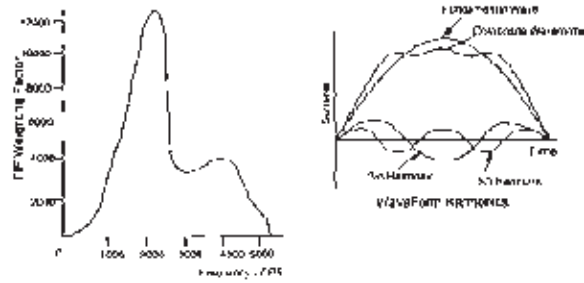

Figure 33.

The waveform distortion discussed above can cause problems in voltage regulation, generator and load overheating, and inaccurate instrument readings. Both voltage and current may have harmonic components. The current components produce heat and are therefore derating factors for the generator as well as system motors. Typically, Caterpillar generators have the lowest total percentage of harmonic voltages available.

Occasionally, specs call for 2/3-pitch stator winding, a common competitive practice in reducing 3rd harmonics. Caterpillar generator design minimizes 3rd harmonic voltage without compromising 5th and 7th. It is, therefore, important for specs to stress the actual total harmonic levels produced by the generator.

One very important factor to remember is that most harmonics are produced by the load itself. Examples are large battery chargers for uninterruptible power supply (UPS) systems, fluorescent lamps and variable speed motor drives.

Each of these harmonic voltages generated are in the windings, but a 3rd harmonic current will not flow in a three-phase, wye connected winding unless the neutral is connected. The 3rd harmonic current will flow in a delta-connected generator winding as shown in Figure 1. Both 5th and 7th harmonics will flow in either winding since they are line harmonics.

The major difficulty caused by harmonic currents is heat generated in the winding, core, and rotor. Since generator ratings are limited by allowable temperature rise, harmonics are, in effect, derating factors. In derating, the magnitude of the current is of obvious importance, because losses are proportional to the square of the current. Increased frequency causes increased core losses and increased copper loss from skin effect. 5th and 7th harmonics are the offenders here because they are in the 600 Hz range.

Another difficulty caused by harmonics is waveform. The more harmonic content in a generated wave, the more distortion from a sine wave occurs. If severe enough, it can cause voltage regulator sensing problems and inaccurate instrument readings.

This section explains the various methods of minimizing harmonics. Some of these methods are:

- Pitch Factor
- Skew Factor
- Waveform Shaping

Most generators are **fractional pitch**. In other words, the stator windings are less than a pole pitch from one coil side to the other (less than 180 electrical degrees apart). Placing the two sides of a coil less than 180 electrical degrees apart reduces the voltage induced by the coil. However, it helps control harmonics, shortens end turns, and simplifies the physical construction of the generator.

The table provided shows the percent reduction of 3rd, 5th, and 7th harmonics at various pitch factors.

	3 rd HARMONICS	5 th HARMONICS	7 th HARMONICS
8/9 PITCH	12%	32%	60%
7/8 PITCH	50%	82%	30%
2/3 PITCH	100%	10%	12%

Percent of Harmonics Reduction

Figure 34.

Another common method of reducing slot harmonics is to **skew** or angle the stator slots. Occasionally, the poles are skewed instead. In either case, the voltage is somewhat reduced, but so are the harmonics.

Adjustments are made in the pole flux waveform and the stator windings to achieve an adequate waveform in the output voltage. The factor “K” accounts for both types of adjustments.

The voltage output waveform can also contain harmonics. It can contain odd harmonics (e.g. 3rd, 5th, 7th, 9th, etc.), but never even harmonics. A quality output voltage waveform must be shaped as sinusoidal as possible to reduce these harmonics. To create an output voltage waveform that is as sinusoidal as possible, the shape of the pole heads is adjusted.

A square pole head generates a square flux wave, which, in turn, generates many odd harmonics in the stator windings.

To make the flux wave more sinusoidal, the pole tips can be beveled. This increases the air-gap length at the pole tips, increasing the reluctance, or resistance, of the flux path.

However, to achieve the best flux waveform possible, the pole face is rounded at a radius with a different center than the stator core.

All generators have **harmonic waveform distortion** and non-sinusoidal rotor flux density. Following is a list of generator design factors for distortion reduction:

- STATOR SLOTS — more stator slots give better winding distribution
- WINDING STYLE — symmetrical lap winding produces the best waveform
- SKEW — one slot pitch skew eliminates ripple harmonics
- SLOT OPENING — the wider the slot opening, the greater the harmonics
- POLE HEAD WIDTH — wider pole heads increase flux distribution
- TAPERED POLE HEADS — tapered pole heads distribute more nearly sinusoidal flux
- STATOR WINDING PITCH — reduces or eliminates certain harmonics, but not all harmonics

Telephone influence factor (TIF) and **telephone harmonic factor (THF)** measure the possible effect of harmonics in a generator wave shape on telephone circuits. TIF and THF are measured at the generator terminals on open circuit at rated voltage and frequency. TIF is used in the US, while THF is used in the rest of the world.

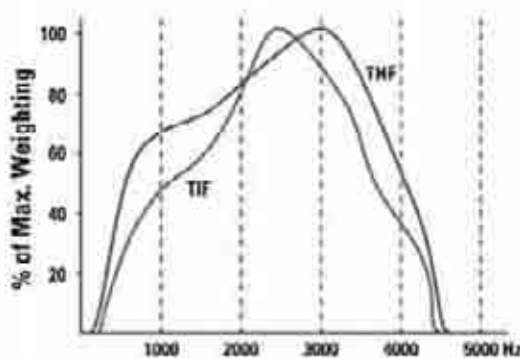

Figure 35.

Shown is a comparison of TIF and THF weighting curves. Weight refers to the sound wave/harmonic with the most emphasis on it. The higher the weight, the more emphasis placed. The calculating procedures are different for TIF and THF, but similar frequencies give almost equal weights.

Limits for generator harmonics are based on these curves. The most annoying frequencies in telephone interference are usually 2500 to 3000 Hz, and therefore have the highest weighting.

TIF is the summation of RMS values of each harmonic in a waveform multiplied by a weighting factor (like those in a weighting curve). The product is squared and added together. TIF is then the ratio of the square root of this sum to the RMS of the entire wave.

“Balanced TIF” is measured at frequencies other than triples (examples of triples: 3rd, 9th, 15th, etc.). Generators of higher voltage (above 2000V) are often required to have “residual TIF” values below 100. “Residual TIF” measures triple frequencies only.

Total Harmonic Distortion (THD) is the ratio of the sum of the interference from all harmonics to the fundamental signal.

Waveform Deviation Factor is an indication of the degree that a generated voltage differs from a perfect sine wave. It is common practice that these factors not exceed 10% of the line-to-line generated voltage at no load. SR 4 Generators do not exceed 5%. This characteristic is also known as Wave-Shape Deviation Factor. Deviation from a perfect sine wave is primarily the result of harmonics, generated as a field pole passes a conductor. There are many design techniques available to make the deviation factor very low. These techniques may or may not have importance when the generator is under normal load.

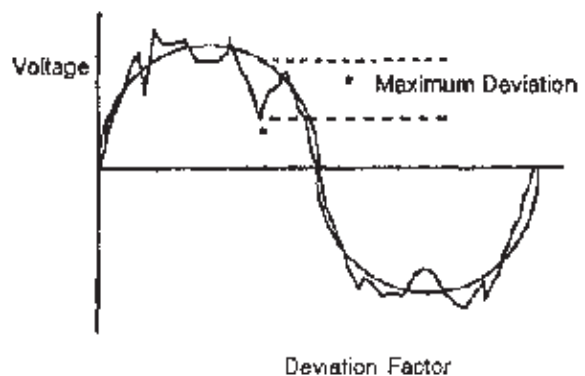

Figure 36.

Percentages of 10% and below are generally acceptable in the industry, although most generator manufacturers meet 5%. Caterpillar generators do not exceed 5% waveform deviation.

Miscellaneous Terms

Overspeed capability is the ability of the generator to handle the sudden increase over rated rpm due to the removal of a large load. This is usually on the order of 125 to 150% of rated rpm.

Heat dissipation occurs when a device is heated due to current flow. Some electrical energy is then lost from the energy used in the heating of this device.

Generator **de-rating** refers to the need to lower a generator's rated operating capabilities due to an environmental reason or a load affect. In other words, using a bigger generator than would be necessary under normal conditions. Several examples of these conditions are as follows:

Altitude

For application over 3300 ft elevation, de-rating of the generator may be necessary. Refer to the altitude/temperature de-rating chart in TMI or consult your Cat dealer.

Ambient Temperature

Where the temperature of the ventilating air to the generator exceeds 40°C (104°F), de-rating of the generator may be necessary. Refer to the altitude/temperature de-rating chart in TMI or consult your Cat dealer. See the chart below for general capabilities:

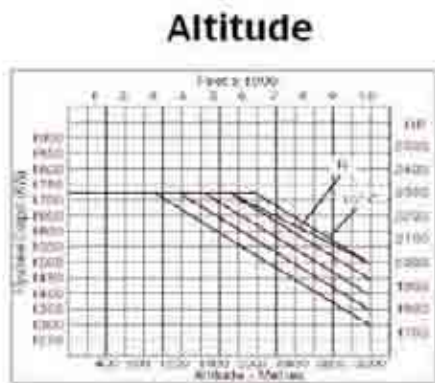

Figure 37.

Non-linear loads & Unbalanced loads generate harmonic currents that cause waveform distortion of the generator. Therefore due to the excess heat created, a larger generator may be needed.

Crest factor is the peak voltage divided by the RMS voltage.

Distortion factor is the sum of the harmonics divided by the RMS voltage.

Generator Limits

Rating limits are occasionally shown in the manner of the graph provided — kVA and kW versus power factor. The fluctuations in the kVA line represent the generator operating limits. It is important to note that every generator's limit characteristics are different and cannot be classified by size, type, etc. For example, the limits for a standby generator are less limiting than for an equivalent prime-continuous generator. Also, for example, field heating limits may be the limiting factor at 0.8 PF, or they may not limit the generator at all.

The engine is many times the limiting factor in a genset as shown by the engine kW limit line.

If the generator operates in the leading quadrant, it operates on a capacitive load and neither the armature nor the field heating limits will be relevant. In this right quadrant, the generator output is only limited by the generator's tendency to become self excited with a high leading power factor.

If the generator operates in the left quadrant of this graph, it has a lagging power factor. It is limited here by both the rotor (field) and stator (armature) heating. Many times, the field temperature limit is lower than the armature limit, especially at low power factor values.

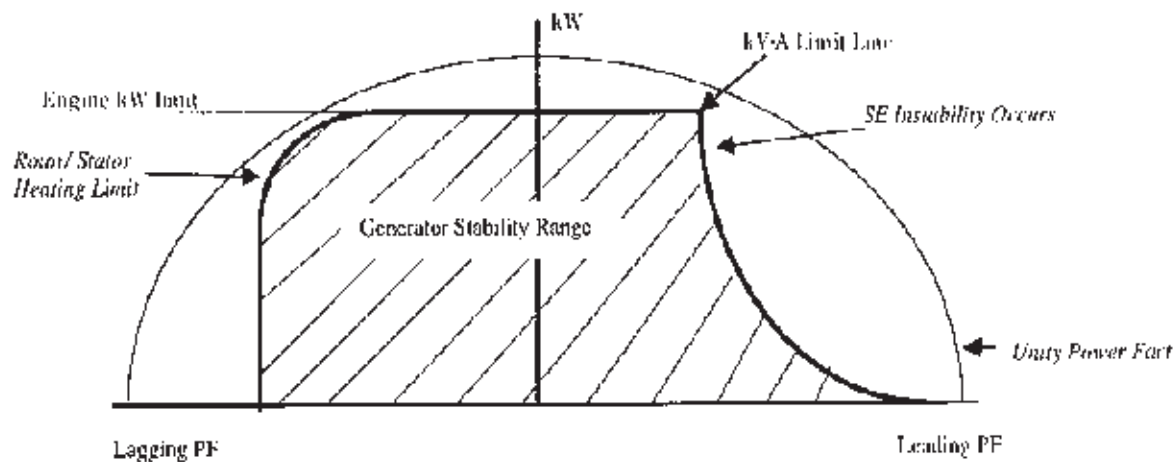

Figure 38.

Exciter & Regulator Characteristics and Performance

Excitation System

Generator voltage is controlled entirely by the exciter-regulator system. The function of the excitation system is to supply DC current to the main generator field windings, enabling them to produce a magnetic field. In turn, this magnetic field enables the stator windings to produce output voltage.

The main generator output voltage should be kept at a constant value for whatever load conditions it may be supporting. Note that there is a drop in voltage at the load terminals due to the impedance of the armature windings and to the reduction of the magnetic field flux. The magnetic field flux is reduced because of the opposing amp-turns of the load current in the armature, known as armature reaction.

Until the 1960's, most engine-driven exciters were DC generators with rotating armatures, stationary fields, commutators, and brushes. The excitation current was fed to the main field (which was mounted on a shaft) through slip rings and brushes. Control of the exciter voltage was accomplished with a variable resistance in the exciter field.

DC exciters are seldom used today though. Adjusting these exciters for close control of saturation, operating point on the curve, and brush and commutator setting is too difficult. Also, the short brush life and commutator

maintenance of this exciter system is unacceptable by today's standards.

In the shunt excitation system, both voltage output sensing and AC power output are taken from three-phase AC generator output lines (represented by one line in the drawing below). The static exciter converts the AC power to DC power (originally by magnetic amplifiers, but presently by SCR's) and feeds the DC power to the main generator field windings.

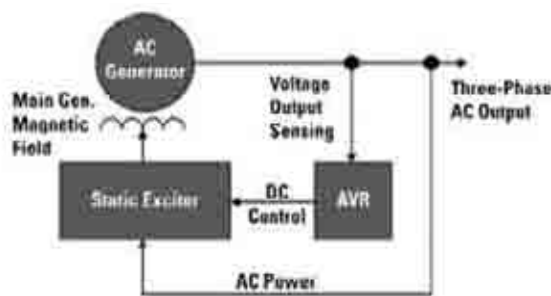

Figure 39.

In a self-regulating system, the voltage and current are taken from the AC generator output lines. The voltage and current are added together so at a power factor of 1.0, they are 90° apart. When the power factor lags, the angle changes to give an increased resultant. The varying resultant is fed through the **rectifier** to the field. The function of rectifiers is to convert the AC current from the exciter to a DC current that can be supplied to the field windings. The rectifier circuits most commonly used are:

1. 3-phase bridge
2. 3-phase star

The generator can be deemed **self excited** (SE) as well. An SE generator uses the output from the main generator to supply its own exciter current. When assembled, a brushless generator contains the functional parts shown. The engine drives the exciter armature, rectifier, & main field, while the main armature, AVR, and exciter field are stationary.

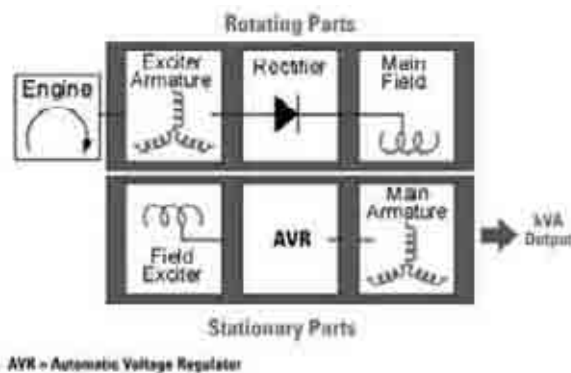

Figure 40.

The **permanent magnet** (PM) or pilot exciter furnishes power to the main exciter, thus, eliminating the main exciter's dependence on generator output voltage. It is in essence a very small generator attached at the end of the same shaft as the main generator. It eliminates the exciter's dependence on output from the main generator making it a more stable device in load transients.

The main generator output voltage should be kept at a constant value for whatever load conditions it may be supporting. A voltage regulator controls this function by controlling the output of the exciter.

Voltage Regulation

Voltage regulation is achieved through the excitation control system. The term "voltage regulation" originates from the inherent regulation of a synchronous generator without an automatic voltage regulator (AVR). A better term than voltage regulation might be voltage accuracy, meaning a voltage that does not deviate from a given value for any reason other than transient load changes. This is considered ideal voltage regulation.

The purpose of the voltage regulator is to control generator output in order to maintain voltage within prescribed limits with changes in loads. There is a misconception in the marketplace that voltage regulation must be $\pm 0.5\%$. While Cat regulators meet this specification, it is important to note that normal utility voltage fluctuates by $\pm 5\%$ or more, which is at least 10 times as much.

Voltage regulation is affected mainly by loading and transients. Other factors that affect voltage regulation include cold-to-hot drift, frequency effect, generator heating effect, and ambient temperature change. Voltage regulation encompasses all variables that must be controlled to keep generator voltage within a given percentage of a specified value.

The AVR senses the voltage level at the generator terminals by comparing it to the reference. The reference in older mechanical AVR's was often a spring or saturating reactor. In present day AVR's, the reference is often a zener diode — a very stable voltage device. The desired voltage level is set by the voltage adjust rheostat. This voltage level is compared to the terminal voltage. The reference in the error detector is fed through the amplifier to the power section (usually triggering an SCR) to feed the exciter field. The power section provides the exciter field with more or less current depending on the error signal requirement. The AVR, for example, may call for increased excitation because of falling terminal voltage. The increased excitation brings the voltage back up, but by the time the AVR senses and responds to the need to drop the excitation once more, the voltage

may tend to overshoot. As a result, oscillations occur. Therefore, the stability circuit anticipates restoration of voltage, so over-correction is avoided.

The excitation control system in a synchronous generator is usually a feedback control system consisting of the exciter and the AVR. Open loop systems are seldom used.

The system components involved in meeting performance specifications are the synchronous generator, the AVR, and the exciter. These three components and their interaction are responsible for the following performance characteristics.

- SYNCHRONOUS GENERATOR — Total harmonic content, maximum single harmonic, crest factor, form factor, deviation factor, and phase voltage balance.
- AVR — Stable recovery voltage, maximum voltage modulation, frequency of modulation, voltage drift with ambient temperature, voltage drift with time, cold-to-hot drift, and voltage regulation. Maintaining voltage regulation means keeping the generator within the specified load range, power factor range, and ambient temperature range.
- GENERATOR AND EXCITER — Maximum voltage dip, maximum voltage overshoot, and recovery time.

The **steady-state voltage variation** is the percentage fluctuation allowed by the voltage regulator under constant load, temperature, and engine speed. Generator sets generally provide much less variation than the normal utility; but in some applications, especially paralleling, close regulation may be a sales advantage. Caterpillar generators have a steady state regulation of $\pm 0.5\%$ from nominal voltage (constant load, constant temperature and constant frequency).

No load to full load voltage regulation is the measure of a generator set's ability to return to rated voltage after the application of a load. Low variation is desirable because voltage drop causes increased current flow and heating in electric motors which can reduce their life. Low voltage can also cause breakers to trip unnecessarily. All Cat generators have 1% N.L. to F.L. regulation.

Caterpillar has led the industry in regulators with **three-phase voltage sensing**. Most Caterpillar generators are equipped to sense three-phase voltage. Three-phase sensing averages all three-voltage phases, resulting in better regulation, especially when the load is unbalanced. The most significant benefit is the ability to handle the three-phase silicon controlled rectifier (SCR) drives used in systems such as un-interruptable power supplies (UPS).

A key requirement of a generator set is its ability to recover from load transients. With a constant voltage regulator, it is possible to overload an engine during load applications to the point that it cannot recover speed. Most modern generators, therefore, utilize a regulator which permits a brief voltage droop proportional to speed droop (volts/hz) upon application of a load. With this **volts per hertz** relationship, the regulator reduces the voltage in proportion to speed when a large block of load is applied causing a drop in engine speed. This reduction in voltage reduces the kW load allowing the engine to recover to rated speed and frequency. The diagrams show a comparison between the response of a constant voltage regulator system to a volts per hertz type. Volts per hertz regulators are standard on Cat generators and available as an option on some competitive generators.

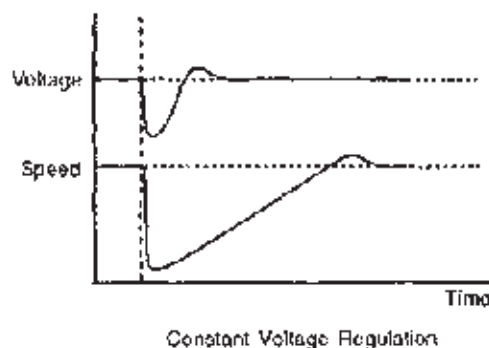

Figure 41.

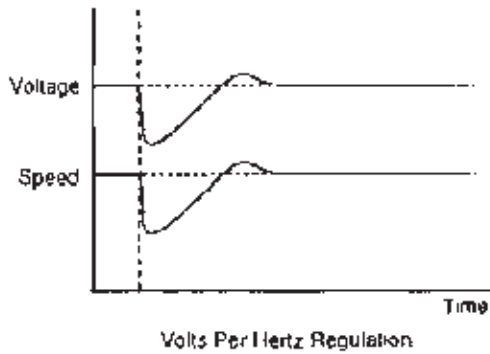

Figure 42.

A **2 volts per hertz** system regulates in the same fashion but the regulation is twice as aggressive. One significant characteristic of the V/Hz curve is a double knee frequency. This refers to the allowed variation in frequency (usually around 2-3 hertz) from the rated frequency before regulation occurs. This difference allows for minor variations in frequency without changing the voltage unnecessarily.

Performance

The line graph provided illustrates the relationship between the AVR and load application. It demonstrates that a transient condition without an AVR (therefore, with constant excitation) causes the terminal voltage of the generator to decrease to a lower voltage until it reaches a steady state. This lower voltage depends upon the generator regulation, sometimes called inherent regulation. For most applications, this inherent regulation is unsatisfactory.

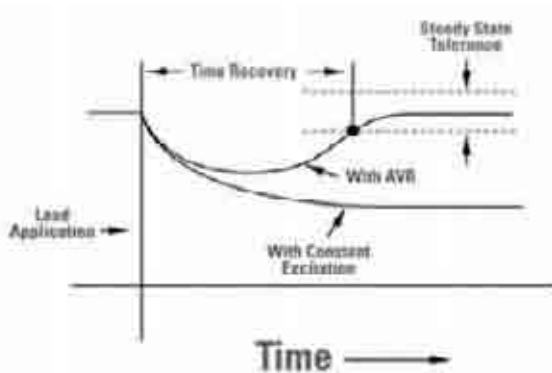

Figure 43.

With an AVR producing a high excitation, the terminal voltage will recover its initial value or a value within the steady-state tolerance. With a solid-state AVR, the recovery is quite rapid.

Note: Steady-state tolerance is the acceptable recovery range for terminal voltage.

The line graph shows the results of faster and slower response times of excitation and regulation systems to a transient load. The voltage dip is greater for the slow response system than for the fast response system. The voltage also continues to follow the inherent regulation characteristic and consequently drops to a lower value than the faster system voltage.

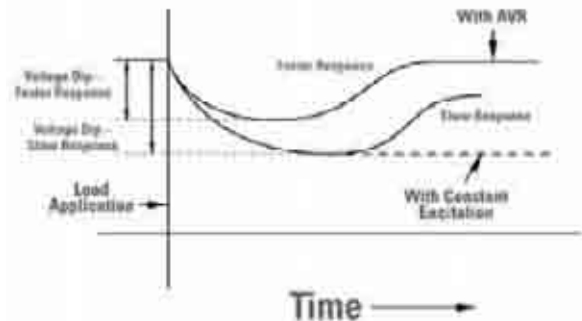

Figure 44.

An inductive coil, such as a field winding, will not allow current to build up immediately. The rate of buildup is determined by what is called a "time constant." The coil time constant is measured in seconds and is inductance (Henrys) divided by resistance (ohms). Thus, a coil with an inductance of 2.0 Henrys and a resistance of 2 ohms would have a time constant of 2.0 divided by 2.0 equals 1.0 seconds. So, 1.0 seconds is required to reach 63% of the final current value of voltage divided by resistance. The current will reach 100% value in five time constants. To continue the example, 100% current will be reached in $5 \times 1.0 = 5.0$ seconds.

Since the excitation system and the generator have several inductive coils within them, their associated time constants will have an effect on how fast the magnetic fields respond to a change in voltage. Even though the AVR may react to a change in output voltage almost

instantaneously, the exciter field, the exciter armature, the main field, and the main generator time constants will prevent a corresponding instantaneous change in generator terminal voltage. These time constants must be taken into account with any transient response time.

The excitation voltage for the exciter field of a brushless generator is provided by the generator output. For steady-state loads and most transient loads, this power is sufficient. However, generator output voltage drops under transient loading. Voltage to the AVR drops, as well. If the voltage drop is severe enough, the reduction in voltage to the exciter field will cause the main generator voltage to collapse or “fold-up.” To avoid this, a booster arrangement (also called a series-boost) is used for generators that might be subjected to extreme loading (e.g. short circuits). The series-boost employs a current transformer, which supplies voltage to the exciter field during high current loading transients. Also, the permanent magnet pilot exciter supplies current to the exciter field independent of the generator output voltage. Therefore, the pilot exciter sustains high current transient loading, as well.

Controlling excitation with the reactive load is one way of sharing the reactive load between paralleled generators.

A broad manual voltage adjustment range is required for some applications, particularly when operating the same generator at 120/208 volts or 240/480 volts. Broad voltage adjustment can go as high as 20%.

Protective features that can be added to a generator excitation system are:

- Over/Under Voltage
- Sensing Loss
- Over-Excitation
- Over-Frequency
- Loss of Excitation

Some of the features listed here are redundant. All of these features would never be needed on any single generator and few of these features would be needed on a small generator set.

Specifications

Voltage regulation specifications are met when the following occurs. The numbers represented by XX will vary depending on the generator set and application.

- 1) Generator voltage accuracy must be within plus or minus XX percent with a frequency change of no more than plus or minus XX percent when the load varies between no load and rated load.
- 2) With constant load, generator voltage must remain within XX percent at an ambient temperature range of XX degrees Celsius to XX degrees Celsius.
- 3) A constant load and ambient temperature generator voltage drift must not exceed XX percent for an XX hour period.
- 4) When the generator is started cold, voltage must not vary more than plus or minus XX percent for the first XX minutes at constant load and ambient temperature.
- 5) Transient Performance — Upon application or rejection of XX load, generator voltage must not vary more than XX percent from the initial voltage and must recover to and stay within XX percent of the initial voltage within XX seconds.

Response time is the time required for the AVR to respond to a specific change in sensed voltage. An AVR uses the following voltage sensing functions.

- **SINGLE-PHASE:** If the load is unbalanced and the loaded phase is sensed, the unloaded phase voltages will be high. If the unloaded phase is sensed, the loaded phase voltage will be low.
- **THREE-PHASE:** The voltage spread between loaded and unloaded phases is equal and is averaged around the true voltage.
- **TRUE RMS:** For 1-phase and 3-phase sensing, true RMS sensing is not affected by irregular waveforms. Waveform tolerance is the amount of non-sinusoidal waveform that can be handled by AVR sensing without loss of accuracy. Radio frequency interference suppression may be added to aid waveform tolerance.

Frequency Sensing

SOFT REGULATION: voltage and frequency dip determines the generator set's ability to pick up large block loads. As the frequency decreases, reducing the voltage reduces the kW load by the square of the voltage (or $P = V \times A$), enabling the engine speed to recover faster. Reducing voltage with frequency also allows the machine to operate at a reduced speed without damage to the exciter or generator field. Voltage reduction can be programmed on some regulators to reduce voltage faster or slower.

HARD REGULATION: with constant volts per hertz, the engine is loaded more and will require more time to recover. Induction motor flux density remains constant. It is, therefore, possible to control motor speed through engine speed control — with certain limitations.

Type

The automatic voltage regulator (**VR3**) is the analog version. It is standard in many small to medium sized generator sets and is the more cost effective of the two types. It can sense in three-phase and also in single-phase in a self-excited set-up as well. It can be configured in a Volts/hertz regulating configuration that provides superior engine speed control and stability. In a VR3F or flat top design the V/Hz slope is twice as steep allowing for added stability and control of overshoot.

The digital voltage regulator (**DVR**) is the digital version of Caterpillar's voltage regulators. RMS sensing is standard on this package which gives it better capabilities. It is typically used in medium to larger sized generator sets. It can provide superior Volts/Hertz regulation since it can be programmed to be application specific.



www.cat-engines.com

© 2000 Caterpillar
All rights reserved.
Printed in U.S.A.

LEBX0025 (04-00)

Materials and specifications are subject to change without notice.

