

TECHNICAL INFORMATION

G3600 GAS ENGINES

G3606 • G3608

G3612 • G3616

CATERPILLAR[®]

Contents

General Data.....	2
Combustion Air System.....	3
Loading on Turbocharger Inlet, Maximum.....	5
Exhaust Gas System.....	6
Loading on Turbocharger Outlet, Maximum.....	6
Fuel System	7
Lubricating Oil System	8
Cooling Water System	11
Block Cooling.....	11
Aftercooling / Oil Cooling.....	12
Starting Air System	13
Starter Performance Curves	13
I-R Starters	13
TDI Starters	15
Additional Data	17
Torsional Vibration Analysis Information	17
Flywheel & Damper Information.....	19
Torsional Vibration Analysis Limits.....	19
Crankshaft Cantilever Loads.....	20
Unbalanced Forces and Moments	21
Rolling Torques	22
Part Load Strategy.....	25
Sound Power Data (Mechanical, Exhaust & Air Inlet)	26

Sound Power Data @ 900 rpm & 100% Load	26
Sound Power Data @ 1000 rpm & 100% Load.....	27
Power Supply Requirements	28
Reference Materials	28

Foreword

This section of the Application and Installation Guide lists Technical Information for Caterpillar® engines listed on the cover of this section. Additional engine systems, components and dynamics are addressed in other sections of this Application and Installation Guide.

Engine-specific information and data are available from a variety of sources. Refer to the Introduction section of this guide for additional references.

Systems and components described in this guide may not be available or applicable for every engine.

Information contained in this publication may be considered confidential. Discretion is recommended when distributing. Materials and specifications are subject to change without notice.

CAT, CATERPILLAR, their respective logos and "Caterpillar Yellow", as well as corporate and product identity used herein, are trademarks of Caterpillar and may not be used without permission.

Technical Information – 3600 Gas Engines

This guide provides technical data for the Caterpillar 3600 gas engine models offered to the Petroleum Market. At the time of publishing, this data is correct; updates will be included periodically and this section republished. Dealers may use the Technical Marketing Information system for the most current data.

SECTION CONTENTS

General Data	2	Additional Data.....	17
<ul style="list-style-type: none"> • Loading on Turbocharger Inlet, Maximum 		<ul style="list-style-type: none"> • Torsional Vibration Analysis Information 	
Combustion Air System	3	<ul style="list-style-type: none"> • Flywheel & Damper Information 	
<ul style="list-style-type: none"> • Loading on Turbocharger Outlet, Maximum 		<ul style="list-style-type: none"> • Torsional Vibration Analysis Information 	
Exhaust Gas System	6	<ul style="list-style-type: none"> • Crankshaft Cantilever Loads 	
<ul style="list-style-type: none"> • Loading on Turbocharger Outlet, Maximum 		<ul style="list-style-type: none"> • Rolling Torques 	
Fuel System	7	<ul style="list-style-type: none"> • Part Load Strategy 	
Lubricating Oil System.....	8	Power Supply Requirements .	28
Cooling Water System.....	11	Reference Materials	28
<ul style="list-style-type: none"> • Block Cooling • AC/OC Cooling 			
Starting Air System.....	13		
<ul style="list-style-type: none"> • Starter Performance Curves 			

General Data

System Description Metric (English)	G3606	G3608	G3612	G3616
Cylinder Bore mm (in)	300 (11.8)	300 (11.8)	300 (11.8)	300 (11.8)
Stroke mm (in)	300 (11.8)	300 (11.8)	300 (11.8)	300 (11.8)
Displacement/Cylinder L (in ³)	21.2 (1294)	21.2 (1294)	21.2 (1294)	21.2 (1294)
Total Displacement L (in ³)	127.2 (7762)	169.6 (10350)	254.4 (15528)	339.2 (20704)
Rated Speed rpm	700 to 1000	700 to 1000	700 to 1000	700 to 1000
Low Idle Speed rpm	550	550	550	550
High Idle Speed - programmable rpm	700 to 1000	700 to 1000	700 to 1000	700 to 1000
Firing Order – CCW	1-5-3-6-2-4	1-6-2-5-8-3-7-4	1-12-9-4-5-8-11-2-3-10-7-6	1-2-5-6-3-4-9-10 -15-16-11-12-13-14-7-8
Crank Radius mm (in)	150 (5.9)	150 (5.9)	150 (5.9)	150 (5.9)
Connecting Rod Length mm (in)	600 (23.6)	600 (23.6)	600 (23.6)	600 (23.6)
Reciprocating Weight N (lbs)	670.5 (150.7)	670.5 (150.7)	670.5 (150.7)	670.5 (150.7)
Dry weight kg (lb)	15,680 (34,568)	19,000 (41,888)	25,084 (55,300)	29,892 (65,900)

Combustion Air System

System Description Metric (English)	G3606	G3608	G3612	G3616
Air Temperature @ Air Cleaner, maximum °C (°F)	45 (113)	45 (113)	45 (113)	45 (113)
High Inlet Air Temperature (low load) 54°C SCAC, warning °C (°F)	82 (180)	82 (180)	82 (180)	82 (180)
High Inlet Air Temperature (high load) 54°C SCAC, warning °C (°F)	72 (162)	72 (162)	72 (162)	72 (162)
High Inlet Air Temperature (low load) 32°C SCAC, warning °C (°F)	72 (162)	72 (162)	72 (162)	72 (162)
High Inlet Air Temperature (high load) 32°C SCAC, warning °C (°F)	57 (135)	57 (135)	57 (135)	57 (135)
Air Inlet Restriction, new/maximum mm H ₂ O (in H ₂ O)	125/380 (5/15)	125/380 (5/15)	125/380 (5/15)	125/380 (5/15)
Aftercooler Pressure Difference @ 100% Load, clean state kPa (psi)	3.4 (0.5)	3.4 (0.5)	3.4 (0.5)	3.4 (0.5)
Air Cleaner Style - Standard Duty without Precleaner *	1-Double Element Housing	1-Double Element Housing	1-Triple Element Housing	2-Double Element Housing
Air Cleaner Style - Heavy Duty with Precleaner *	1-Triple Element Housing	1-Triple Element Housing	2-Triple Element Housing	2-Triple Element Housing
Air Inlet Restriction, maximum limit with dirty air cleaner elements kPa (in H ₂ O)	3.7 (15)	3.7 (15)	3.7 (15)	3.7 (15)
Air Inlet Restriction, design guideline for new clean system kPa (in H ₂ O)	1.3 (5)	1.3 (5)	1.3 (5)	1.3 (5)
Aftercooler Pressure Difference @ 100% Load, clean state kPa (psi)	3.4 (0.5)	3.4 (0.5)	3.4 (0.5)	3.4 (0.5)

* See Price List for full descriptions of latest offerings.

Clean filters cause little air restriction. The addition of precleaners before the air cleaner extends the filter service period. A flow restriction of 0.25 to 0.75 kPa (1 to 3 in).

Air Inlet Ducting Design Guidelines:

Keep Flow Restriction of the air ducting below 0.5kPa (2 in H₂O)

Ducting should have welded seam piping or seamless piping to minimize the flow restriction. PVC piping is recommended.

Ducting must withstand a minimum vacuum of 12.5 kPa (50 in H₂O) for structural integrity.

Air Cleaner Performance Curves

Airflow m³/min - Corrected to 721 mm Hg & 25°C

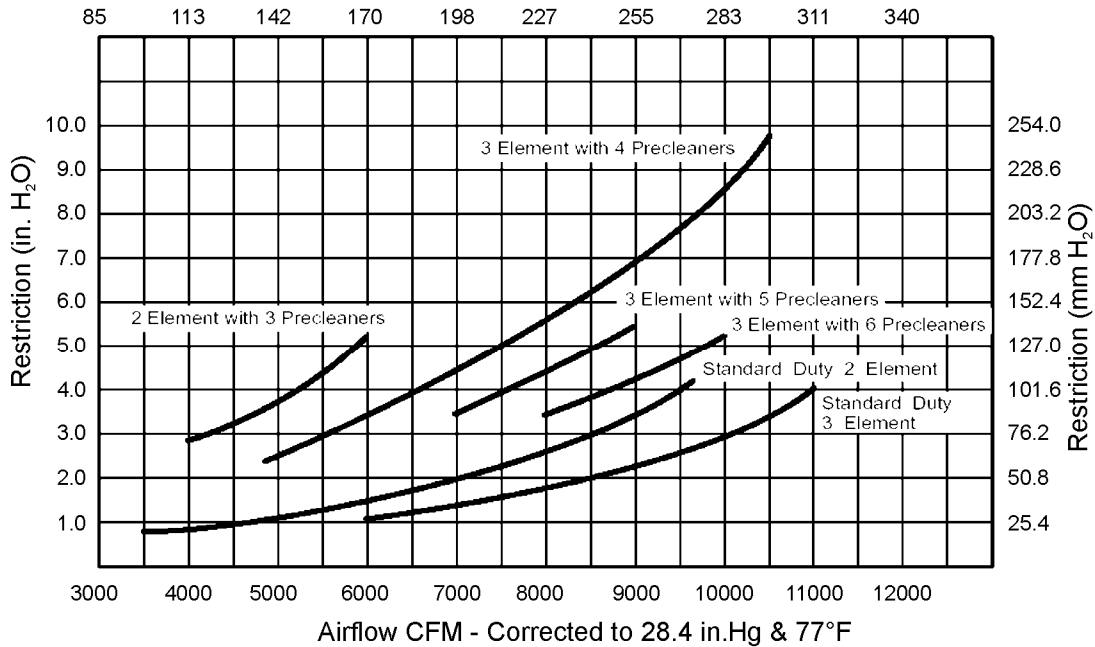

Maximum allowable total inlet restriction should not exceed 3.7 kPa (15 in. H₂O) with dirty air cleaner elements and 1.2 kPa (5 in. H₂O) with initial clean elements.

Air cleaner housings supplied by Caterpillar are provided with an indicator set for a maximum restriction of 3.7 kPa (15 in. H₂O).

Loading on Turbocharger Inlet, Maximum

Maximum Loads for ABB VTC Turbocharger Intake

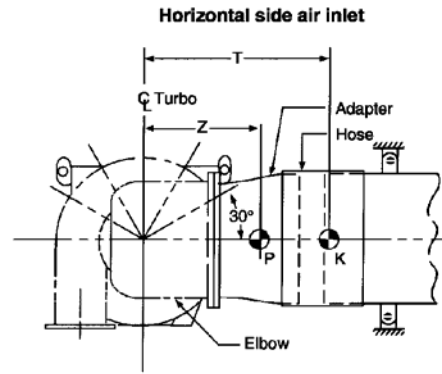
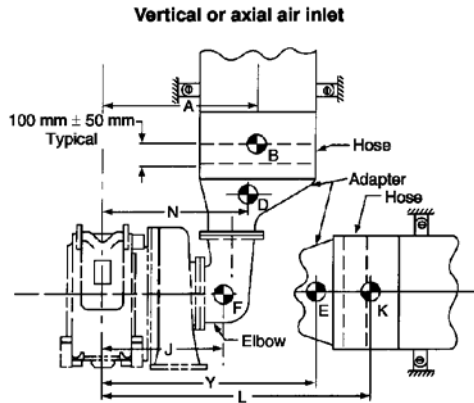

D, F & E = Adapter Weight
 B & K = 1/2 Hose Weight
 Movement (Vertical Inlet):
 $M_v = JF + ND + AB$
 Movement (Axial Inlet):
 $M_a = YE + LK$

Allowable Maximum Moment = 294 N•m

P = Adapter Weight
 K = 1/2 Hose Weight
 $MS = ZP + TK \quad 68 \text{ N•m}$

With Caterpillar Supplied Hardware

J = 548 mm D = 13 kg
 Y = 705 mm E = 14 kg
 N = 625 mm F = 16 kg
 L = 945 mm B = 3 kg/2
 A = 700 mm K = 3 kg/2

$M_v = [0.548(16) + 0.625(13) + 0.700(1.5)] \times 9.6 \text{ m/s}^2$
 $M_v = 176 \text{ N•m}$ which is less than 294 N•m ∴ OK
 $M_a = [0.705(14) + 0.945(1.5)] \times 9.8 \text{ m/s}^2 =$
 $111 \text{ N•m} < 294 \text{ N•m} \therefore \text{OK}$

With Caterpillar Supplied Hardware

Z = 420 mm P = 13 kg
 T = 500 mm K = 3 kg/2

$M_s = [0.420(13) + 0.500(3/2)] \times 9.8 \text{ m/s}^2 =$
 $61 \text{ N•m} < 68 \text{ N•m} \therefore \text{OK}$

Exhaust Gas System

System Description Metric (English)	G3606	G3608	G3612	G3616
Exhaust Outlet Connection mm (in)	Single 355 (14)	Single 355 (14)	Dual 355 (14)	Dual 355 (14)
Exhaust System Backpressure, Maximum mm H ₂ O (in H ₂ O)	305 (12)	305 (12)	305 (12)	305 (12)
Loading on Turbocharger Outlet, Maximum	The bellows and adapter supplied by Caterpillar account for the maximum allowable loading on the turbocharger. All other external piping must be self-supporting.			

Loading on Turbocharger Outlet, Maximum

Vertical Exhaust

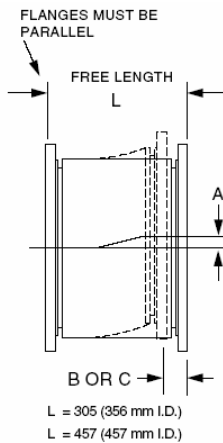
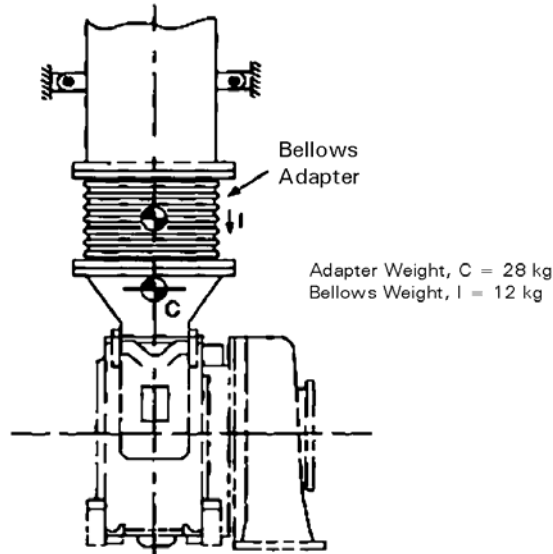

Operational Limitations Of Bellows - Type Flexible Exhaust Fittings					
A Max. Offset Between Flanges		B Max. Compression From Free Length		C Max. Extension From Free Length	
356 mm (14 in.) I.D.					
mm	in.	mm	in.	mm	in.
0	0	99.06	3.90	52.32	2.06
22.20	.87	0	0	0	0
Spring rate of bellows = 55.8 kN / m (318.7 lb/in.) : Axial 163.9 kN / m (936.0 lb/in.) : Lateral					
457 mm (18 in.) I.D.					
mm	in.	mm	in.	mm	in.
0	0	100.00	3.94	50.00	1.97
30.00	1.18	0	0	0	0
Spring rate of bellows = 13.37 kN / m (76.4 lb/in.) : Axial 25.7 kN / m (146.8 lb/in.) : Lateral					
<i>Lagging or insulation must not restrain flexibility of bellows.</i>					

Fuel System

System Description Metric (English)	G3606	G3608	G3612	G3616
Fuel Pressure, nominal kPa (psi)	310 ± 14 (45 ± 2)	310 ± 14 (45 ± 2)	310 ± 14 (45 ± 2)	310 ± 14 (45 ± 2)

Lubricating Oil System

System Description Metric (English)	G3606	G3608	G3612	G3616
Engine Oil Pressure, nominal kPa (psi)	430 (62)	430 (62)	430 (62)	430 (62)
Low Engine Oil Pressure, warning (0 – 600 rpm) kPa (psi)	175 (25)	175 (25)	175 (25)	175 (25)
Low Engine Oil Pressure, warning (600 – 1000 rpm) kPa (psi)	400 (58)	400 (58)	400 (58)	400 (58)
Low Engine Oil Pressure, shutdown (0 – 600 rpm) kPa (psi)	100 (15)	100 (15)	100 (15)	100 (15)
Low Engine Oil Pressure, shutdown (600 – 1000 rpm) kPa (psi)	350 (51)	350 (51)	350 (51)	350 (51)
Engine Oil Temperature, nominal °C (°F)	83 (181)	83 (181)	83 (181)	83 (181)
High Engine Oil Temperature, warning °C (°F)	88 (190)	88 (190)	88 (190)	88 (190)
High Engine Oil Temperature, shutdown °C (°F)	90 (194)	90 (194)	90 (194)	90 (194)
Prelube Pump Capacity, intermittent (pneumatic) Lpm (gpm)	76 (20)	76 (20)	76 (20)	76 (20)
Prelube Pump Capacity, intermittent (electric) Lpm (gpm)	50 – 65 (13 – 17)	50 – 65 (13 – 17)	50 – 65 (13 – 17)	50 – 65 (13 – 17)
Oil Sump Capacity L (gal)	708 (187)	912 (241)	1030 (272)	1325 (350)
BSOC @ 100% Load, typical g/bkW-hr (lb/bhp-hr)	0.304 (0.000521)	0.304 (0.000521)	0.304 (0.000521)	0.304 (0.000521)
Oil Filter Differential Pressure, warning kPa (psi)	100 (15)	104 (15)	104 (15)	104 (15)
Oil Filter Differential Pressure, shutdown kPa (psi)	300 (45)	300 (45)	300 (45)	300 (45)
Emergency Oil Pump Flow Rate Lpm (gpm)	750 (198)	770 (203)	890 (235)	1200 (317)

System Description Metric (English)	G3606	G3608	G3612	G3616
Main Oil Pump Flow Rate @ 900 rpm ⁽¹⁾ low speed pump ⁽²⁾ Lpm (gpm)	1260 (333)	1470 (388)	1630 (430)	2050 (540)
Main Oil Pump Flow Rate @ 900 rpm ⁽¹⁾ high speed pump ⁽³⁾ Lpm (gpm)	1000 (263)	1260 (333)	1470 (388)	1630 (430)
Main Oil Pump Flow Rate @ 1000 rpm ⁽¹⁾ low speed pump ⁽²⁾ Lpm (gpm)	1400 (370)	1630 (431)	1810 (477)	2280 (600)
Main Oil Pump Flow Rate @ 1000 rpm ⁽¹⁾ high speed pump ⁽³⁾ Lpm (gpm)	1100 (293)	1400 (370)	1630 (431)	1810 (477)
(1) Engine speed				
(2) Low speed pumps are used for variable speed applications ranging from 800 to 1000 rpm.				
(3) High speed pumps are used for constant speed applications at 900 or 1000 rpm.				

Tilt Angle Capability

Continuous Tilt Angle Capability							
	Marine Propulsion					Marine Auxiliary	
Tilt Criteria	+/- 10° Trim & +/- 22.5° List (any combination)					+/- 10° Trim & +/- 22.5° List (any combination)	
	Installation Angle / Rear Down (Degrees)						Level Installation
Engine Model	0	1	2	3	4	5	
3606	X	X	X	X	X	X	X
3608	X	X	X	S	S	S	X
3612	X	X	X	X	X	X	X
(Standard Pan)							
3612	Y	Y	Y	Y	Y	D	Y
(Shallow Pan)							
3616	X	X	X	X	S	S	X

X = Standard Sump, capable of meeting the indicated tilt criteria.
 Y = Optional Sump for 3612, capable of meeting the indicated tilt criteria.
 S = Requires increased depth oil sump (special order)
 D = Requires Dry Sump option to achieve the indicated tilt criteria.

Note: If the sump engine is installed at >0° tilt, it will reduce oil capacity and reduce the oil change interval. Consult Caterpillar for specific details.

Cooling Water System

Block Cooling

System Description Metric (English)	G3606	G3608	G3612	G3616
High Engine Coolant Temperature, warning (88°C Jacket Water) °C (°F)	93 (199)	93 (199)	93 (199)	93 (199)
High Engine Coolant Temperature, shutdown (88°C Jacket Water) °C (°F)	98 (208)	98 (208)	98 (208)	98 (208)
High Engine Coolant Temperature, warning (99°C Jacket Water) °C (°F)	105 (221)	105 (221)	105 (221)	105 (221)
High Engine Coolant Temperature, shutdown (99°C Jacket Water) °C (°F)	110 (230)	110 (230)	110 (230)	110 (230)
Temperature Rise, design °C (°F)	4.5 (8)	4.5 (8)	4.5 (8)	4.5 (8)
Temperature Rise, maximum °C (°F)	6 (11)	6 (11)	6 (11)	6 (11)
Low Engine Coolant Temperature, warning °C (°F)	22 (77)	22 (77)	22 (77)	22 (77)
Minimum Inlet Coolant Temperature °C (°F)	0 (32)	0 (32)	0 (32)	0 (32)
Maximum Combined Static & Dynamic Pressure Limit, engine block kPa (psi)	461 (67)	461 (67)	461 (67)	461 (67)
Maximum Combined Static & Dynamic Pressure Limit, pump inlet kPa (psi)	145 (21)	145 (21)	145 (21)	145 (21)
Minimum Static Pressure, pump inlet kPa (psi)	21 (3)	21 (3)	21 (3)	21 (3)
Minimum Dynamic Pressure, pump inlet kPa (psi)	32 (4.7)	32 (4.7)	32 (4.7)	32 (4.7)
Maximum Combined Static & Dynamic Pressure Limit, expansion tank kPa (psi)	150 (22)	150 (22)	150 (22)	150 (22)
Maximum Combined Static & Dynamic Pressure Limit, expansion tank pressure cap kPa (psi)	49 (7)	49 (7)	49 (7)	49 (7)
High Inlet Jacket Water Pressure, shutdown kPa (psi)	462 (67)	462 (67)	462 (67)	462 (67)
Low Outlet Jacket Water Pressure, shutdown kPa (psi)	138 (20)	138 (20)	138 (20)	138 (20)

Maximum Flow Limit, cylinder block Lpm (gpm)	1600 (422)	1600 (422)	3000 (794)	3000 (794)
Jacket Water Circuit Engine Volume* L (gal) *Does NOT include expansion tank volume.	340 (90)	470 (124)	670 (177)	900 (238)

Aftercooling / Oil Cooling

System Description Metric (English)	G3606	G3608	G3612	G3616
Inlet Temperature, nominal (54°C SCAC) °C (°F)	54 (129)	54 (129)	54 (129)	54 (129)
Inlet Temperature, nominal (32°C SCAC) °C (°F)	32 (90)	32 (90)	32 (90)	32 (90)
Temperature Rise, design °C (°F)	7 (13)	9 (16)	8 (14)	10 (18)
Temperature Rise, maximum °C (°F)	12 (22)	12 (22)	12 (22)	12 (22)
Minimum Inlet Coolant Temperature °C (°F)	25 (77)	25 (77)	25 (77)	25 (77)
Maximum Combined Static & Dynamic Pressure Limit, aftercooler kPa (psi)	330 (48)	460 (67)	460 (67)	460 (67)
Maximum Combined Static & Dynamic Pressure Limit, oil cooler – shell & tube kPa (psi)	1000 (145)	1000 (145)	1000 (145)	1000 (145)
Minimum Static Pressure, pump inlet kPa (psi)	21 (3)	21 (3)	21 (3)	21 (3)
Minimum Dynamic Pressure, pump inlet kPa (psi)	19 (2.8)	19 (2.8)	19 (2.8)	19 (2.8)
Maximum Flow Limit, aftercooler lpm (gpm)	800 (212)	800 (212)	1475 (390)	1475 (390)
Maximum Flow Limit, oil cooler – shell & tube lpm (gpm)	1000 (265)	1000 (265)	1000 (265)	1000 (265)
Aftercooler / Oil Cooler Circuit Engine Volume L (gal)	60 (16)	60 (16)	64 (17)	72 (19)

Starting Air System

System Description Metric (English)	G3606	G3608	G3612	G3616
Low Air Pressure, alarm kPa (psi)	750 (109)	750 (109)	750 (109)	750 (109)
Breakaway Torque* N•m (in lb)	2700 (1990)	3400 (2510)	5000 (3690)	6000 (4430)
Cranking Torque** at 10°C (50°F) N•m (in lb)	2250 (1660)	3000 (2210)	4500 (3320)	5500 (4060)
Breakaway Torque ** at 25°C (77°F) N•m (in lb)	1750 (1290)	2250 (1660)	3700 (2730)	4250 (3130)
Breakaway Torque ** at 80°C (176°F) N•m (in lb)	800 (590)	1000 (740)	1800 (1330)	2250 (1660)

* Breakaway torque is independent of oil viscosity or temperature.

** Oil viscosity and temperature are significant factors in the amount of torque needed to crank the engine at a specific speed.
Values are provided with SAE 40 Wt Oil.

Starter Performance Curves

I-R Starters

SS825 Vane Starter (225 psi)

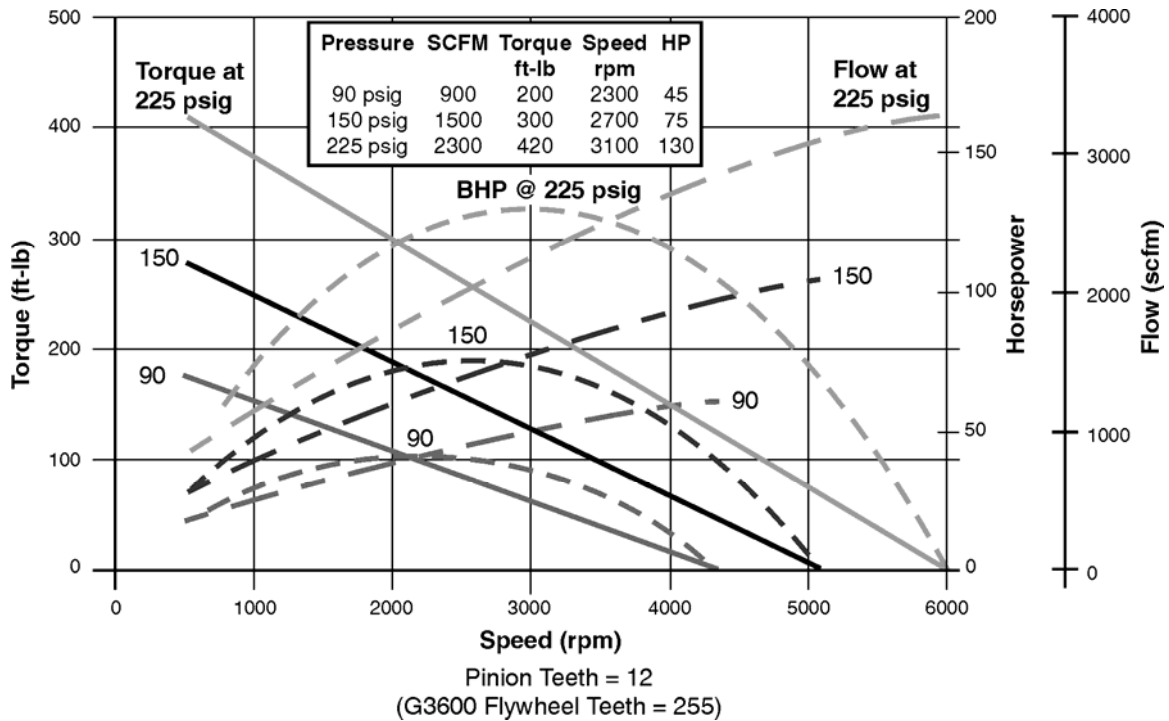

ST950 Turbine Starter (150 psig)

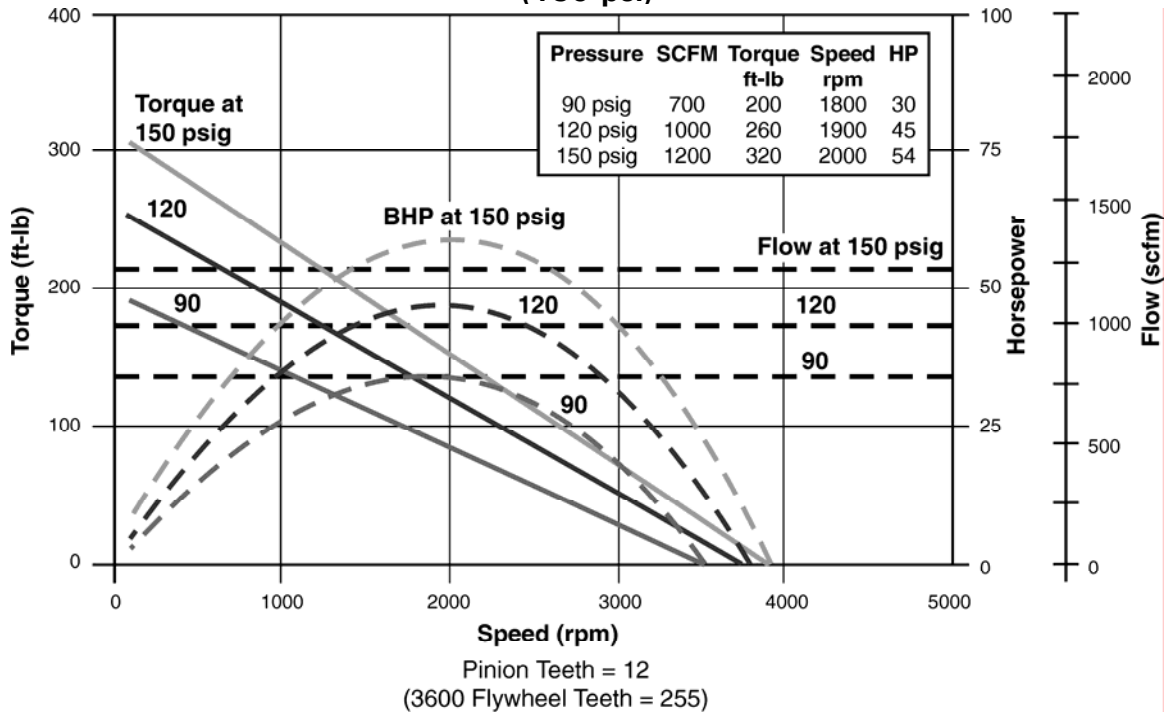

ST999 Turbine Starter (90 psi)

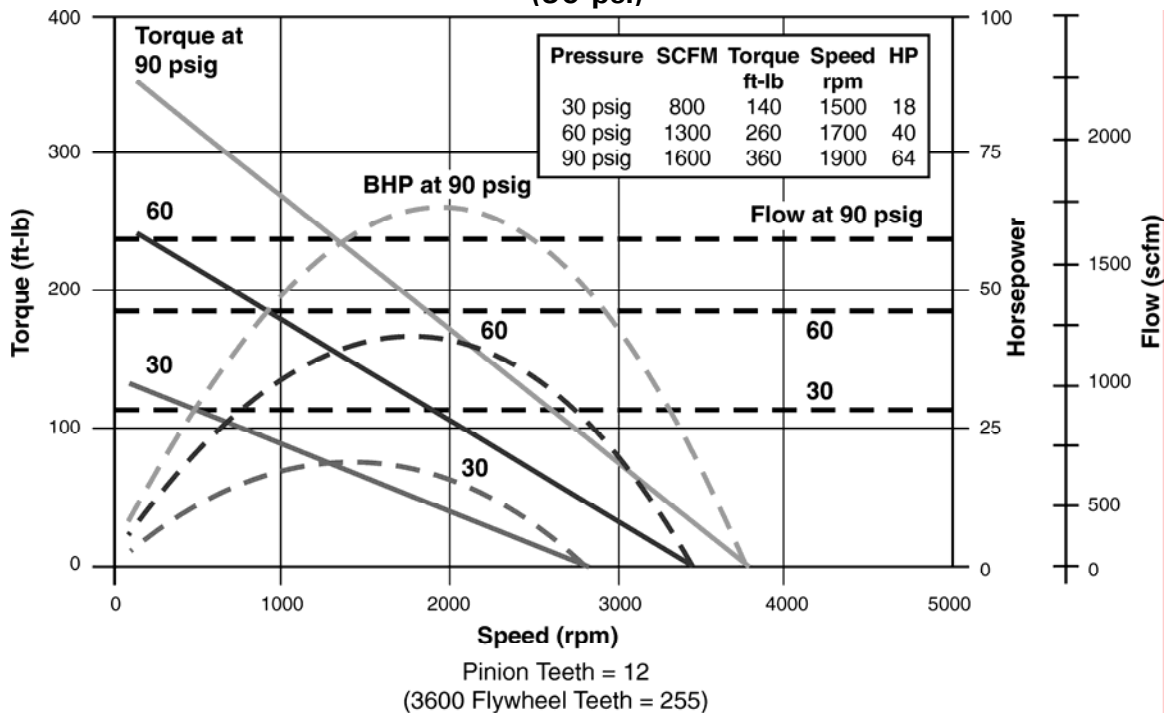

TDI Starters

**T109-V Turbine Starter
(150 psi, 2 per engine for G3612/G3616)**

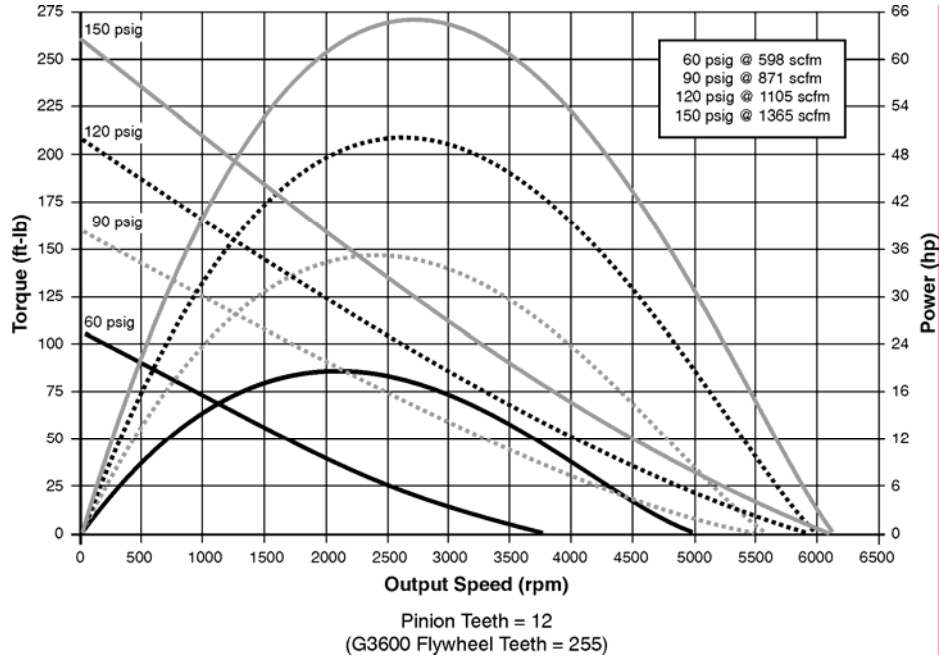

**TDI T112 V Turbine Starter
(150 psi, 1 per engine for G3606/G3608)**

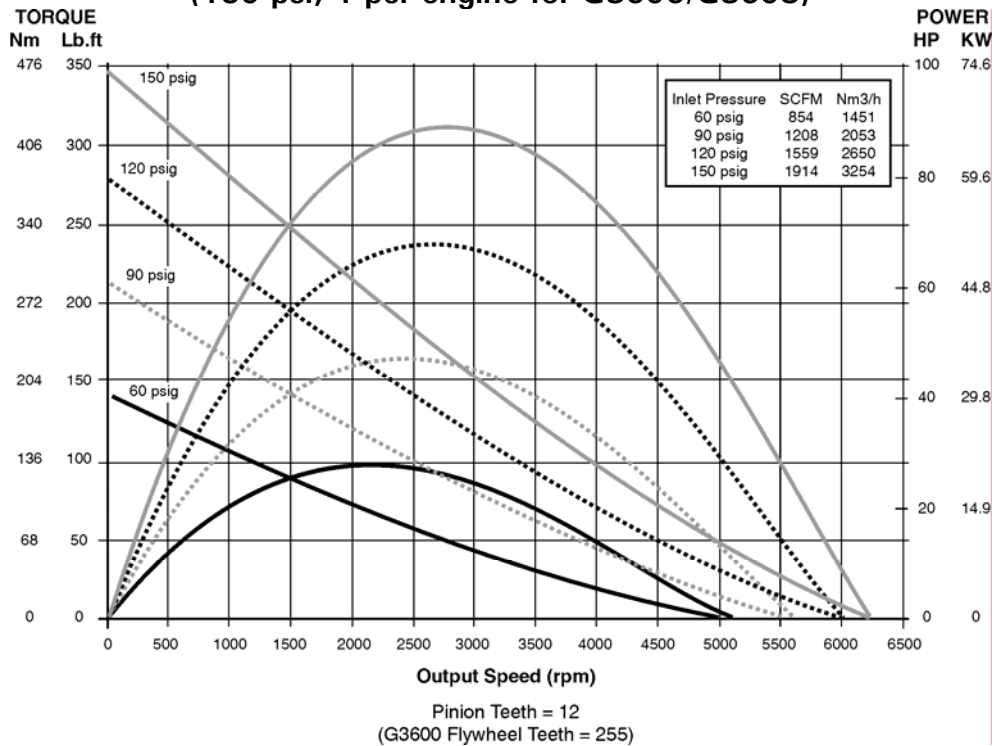

**TDI T121 V Air Starter
(90 psi, 2 per engine for G3612/G3616,
1 per engine for G3606/G3608)**

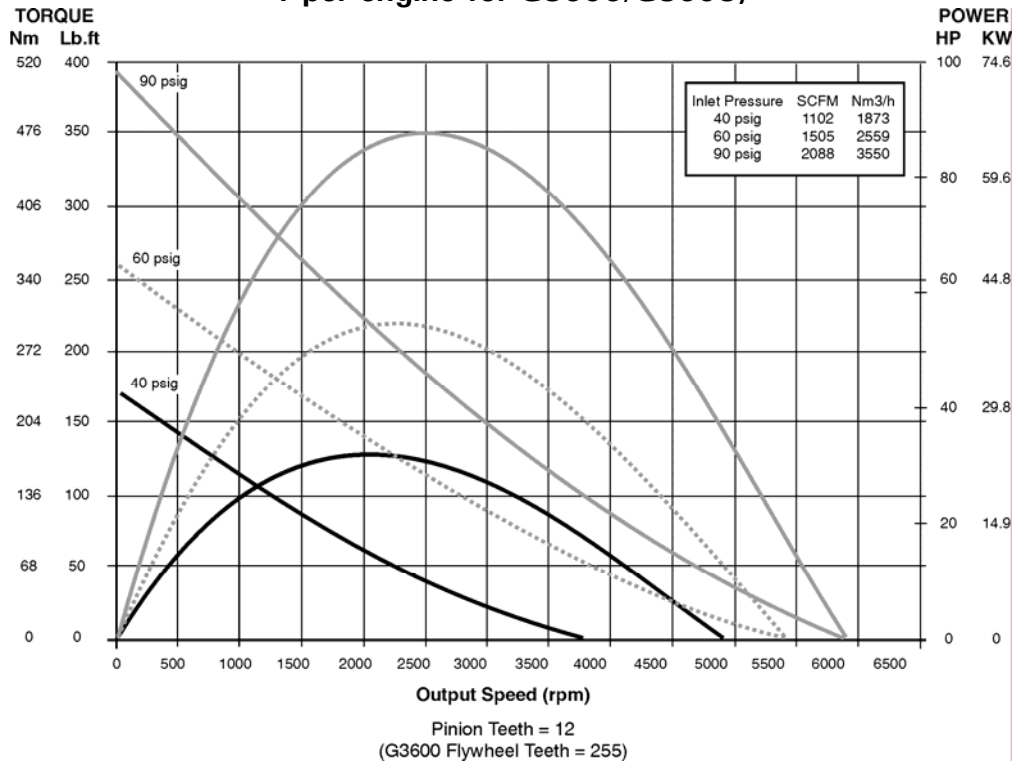

Additional Data

Torsional Vibration Analysis Information

G3606 Engine Mass Elastic Data				
Mass ID	Inertia (N-m-s ²)	Spring ID	Stiffness MN-m/rad	Diameter (mm)
VD	*			
FRT	5.4652	EK1	72.53	216
EJ1	9.743	EK2	42.85	216
EJ2	8.685	EK3	42.85	216
EJ3	8.685	EK4	42.85	216
EJ4	8.685	EK5	42.85	216
EJ5	8.685	EK6	42.85	216
EJ6	9.743	EK7	72.53	216
REAR	5.8060			
FW	*			
* See separate table for damper and flywheel information				

G3608 Engine Mass Elastic Data				
Mass ID	Inertia (N-m-s ²)	Spring ID	Stiffness MN-m/rad	Diameter (mm)
VD	*			
FRT	5.6452	EK1	69.28	216
EJ1	9.434	EK2	41.50	216
EJ2	8.997	EK3	41.50	216
EJ3	8.997	EK4	41.50	216
EJ4	8.997	EK5	41.50	216
EJ5	8.997	EK6	41.50	216
EJ6	8.997	EK7	41.50	216
EJ7	8.997	EK8	41.50	216
EJ8	9.434	EK9	69.28	216
REAR	5.9203			
FW	*			
* See separate table for damper and flywheel information				

G3612 Engine Mass Elastic Data				
Mass ID	Inertia (N-m-s ²)	Spring ID	Stiffness MN-m/rad	Diameter (mm)
VD	*			
FRT	5.6452	EK1	67.80	216
EJ1	17.000	EK2	40.11	216
EJ2	16.320	EK3	40.11	216
EJ3	16.320	EK4	40.11	216
EJ4	16.320	EK5	40.11	216
EJ5	16.320	EK6	40.11	216
EJ6	17.000	EK7	67.80	216
REAR	5.8263			
FW	*			
* See separate table for damper and flywheel information				

G3616 Engine Mass Elastic Data				
Mass ID	Inertia (N-m-s ²)	Spring ID	Stiffness MN-m/rad	Diameter (mm)
VD	*			
FRT	5.6452	EK1	67.80	216
EJ1	17.170	EK2	40.11	216
EJ2	16.500	EK3	40.11	216
EJ3	16.500	EK4	40.11	216
EJ4	16.500	EK5	40.11	216
EJ5	16.500	EK6	40.11	216
EJ6	16.500	EK7	40.11	216
EJ7	16.500	EK8	40.11	216
EJ8	17.170	EK9	67.80	216
REAR	5.8263			
FW	*			
* See separate table for damper and flywheel information				

Flywheel & Damper Information

System Description Metric (English)	G3606	G3608	G3612	G3616
Engine Flywheel Group	6I-2074	6I-2074	6I-2075	6I-2075
Engine Ring Gear Group	9Y-1851	9Y-1851	9Y-1851	9Y-1851
Engine Flywheel & Ring Gear Inertia Kg-m ²	76.97	76.97	76.97	76.97
Damper Group	1W-0791	7W-0127	7W-0127	1W-0864
Damper Housing Inertia Kg-m ²	3.64	11.69	11.69	8.31
Damper Flywheel Inertia Kg-m ²	5.84	29.2	29.2	28.9
Damper Stiffness MN-m/rad	0.73	2.85	2.85	1.35
Damper Absolute Damping N•m-sec/rad	1243	7000	7000	8100
Damper Surface Area m ²	0.5788	1.654	1.654	1.11
Damper Heat Limit, 1000 rpm Kw/m ²	5.7	5.7	5.7	5.7

Torsional Vibration Analysis Limits

System Description	G3606	G3608	G3612	G3616
Engine Front End Amplitude Limits, 0.5 and 1 st orders	± 1.00 degree	± 1.00 degree	± 1.00 degree	± 1.00 degree
Engine Front End Amplitude Limits, 1.5 order	± 0.25 degree	± 0.25 degree	± 0.25 degree	± 0.25 degree
Engine Front End Amplitude Limits, all orders above 1.5	± 0.15 degree	± 0.15 degree	± 0.15 degree	± 0.15 degree
Crankshaft Stress Limits, single order	± 21 MPa	± 21 MPa	± 21 MPa	± 21 MPa
<i>In the event the above limits are exceeded, the customer needs to contact Caterpillar.</i>				

Crankshaft Cantilever Loads

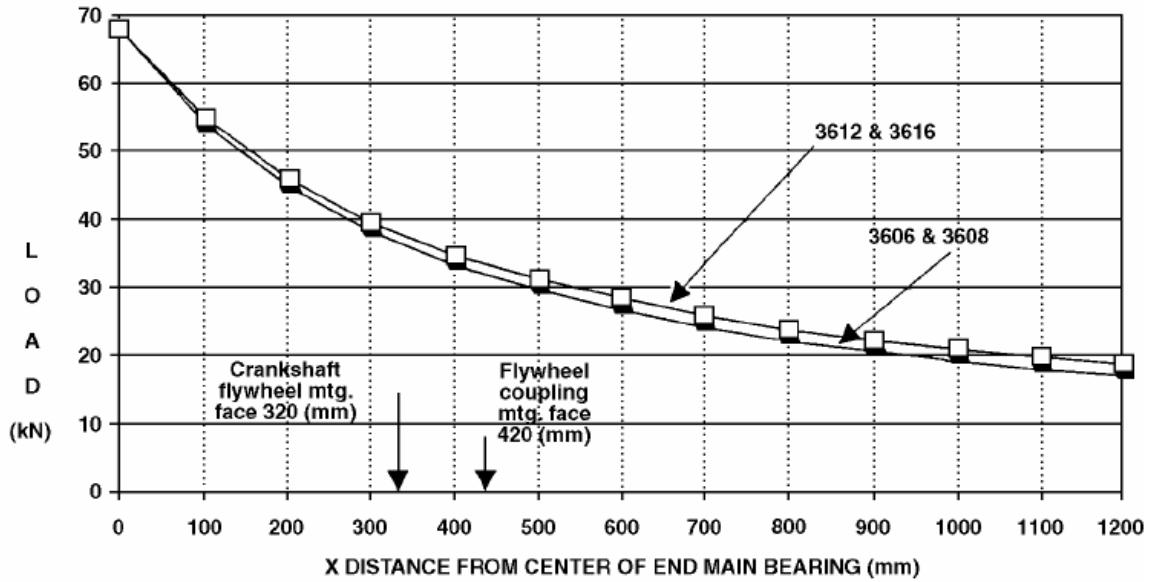

Note: For a given distance, the cantilever load must not exceed the allowable load limit.

Unbalanced Forces and Moments

The following data is based on the assumption that engine components may be machined to a maximum/minimum permissible weight tolerance and assembled in such a manner that produces maximum unbalanced forces and couples. An unbalanced assembly that produces a maximum unbalanced force tends to produce a minimum unbalanced couple and vice-versa. It is to be noted that these are maximum calculated values and standard assembly procedures rarely produce such extreme conditions.

Maximum Unbalanced Forces and Moments for G3606 Engine Due to Manufacturing Tolerances				
Note: 1 X 23" (3600) damper is used in the estimation.				
Engine rpm	Primary Force (kg)		Secondary Force (kg)	
	Vertical	Horizontal	Vertical	Horizontal
700	247	215	16	11
800	323	280	21	15
900	408	355	27	18
1000	504	438	33	23
Engine rpm	Primary Couple (kg-m)		Secondary Couple (kg-m)	
	Vertical	Horizontal	Vertical	Horizontal
700	275	236	17	2
800	359	308	22	3
900	454	390	27	5
1000	560	482	34	7

Maximum Unbalanced Forces and Moments for G3608 Engine Due to Manufacturing Tolerances				
Note: 2 X 30" Narrow Dampers (7C-2122) are used in the estimation.				
Engine rpm	Primary Force (kg)		Secondary Force (kg)	
	Vertical	Horizontal	Vertical	Horizontal
700	244	213	13	9
800	318	278	17	12
900	403	352	22	15
1000	497	435	27	19
Engine rpm	Primary Couple (kg-m)		Secondary Couple (kg-m)	
	Vertical	Horizontal	Vertical	Horizontal
700	378	334	19	4
800	494	437	25	6
900	625	553	31	10
1000	772	682	38	16

Maximum Unbalanced Forces and Moments for G3612 Engine Due to Manufacturing Tolerances				
Note: 2 X 30" Narrow Dampers (7C-2122) are used in the estimation.				
Engine rpm	Primary Force (kg)		Secondary Force (kg)	
	Vertical	Horizontal	Vertical	Horizontal
700	274	154	20	9
800	358	201	26	12
900	454	254	34	15
1000	560	314	41	19

Engine rpm	Primary Couple (kg-m)		Secondary Couple (kg-m)	
	Vertical	Horizontal	Vertical	Horizontal
700	348	209	23	3
800	454	273	30	4
900	575	345	38	7
1000	710	426	47	11

Maximum Unbalanced Forces and Moments for G3616 Engine Due to Manufacturing Tolerances				
Note: 30" Wide Damper (7C-2123) is used in the estimation.				
Engine rpm	Primary Force (kg)		Secondary Force (kg)	
	Vertical	Horizontal	Vertical	Horizontal
700	256	191	29	13
800	335	249	38	17
900	424	315	48	22
1000	523	389	60	27

Engine rpm	Primary Couple (kg-m)		Secondary Couple (kg-m)	
	Vertical	Horizontal	Vertical	Horizontal
700	443	337	47	9
800	579	441	61	15
900	733	558	78	23
1000	904	689	96	36

Rolling Torques

Maximum Rolling moment/torque: It is the phased summation maximum of all cylinders over one full engine cycle (720°)

Minimum Rolling moment/torque: It is the phased summation minimum of all cylinders over one full engine cycle (720°)

The following assumptions are used in calculating the rolling moments:

1. Engine block is assumed very rigid.
2. Gas pressures in combination with vertical inertial forces exert a rolling moment on the engine block.

G3616 Rolling Torque (Full Load)					
Pressure Ratio	Speed (rpm)	Rolling Torque (lb-in)		Maximum Torque (lb-in)	Minimum Torque (lb-in)
9.2:1	900	4 th order	64,200	448,000	225,000
		8 th order	49,000		
		12 th order	32,000		
9.2:1	1000	4 th order	62,500	447,000	225,000
		8 th order	49,000		
		12 th order	32,000		
11.1:1	900	4 th order	65,300	513,000	256,000
		8 th order	69,300		
		12 th order	27,000		
11.1:1	1000	4 th order	62,200	512,000	257,000
		8 th order	69,300		
		12 th order	27,000		

G3612 Rolling Torque (Full Load)					
Pressure Ratio	Speed (rpm)	Rolling Torque (lb-in)		Maximum Torque (lb-in)	Minimum Torque (lb-in)
9.2:1	900	3 rd order	45,500	395,000	170,000
		6 th order	56,300		
		9 th order	22,800		
		12 th order	23,900		
9.2:1	1000	3 rd order	47,000	387,000	177,000
		6 th order	56,300		
		9 th order	22,800		
		12 th order	23,900		
11.1:1	900	3 rd order	62,000	467,000	164,000
		6 th order	119,700		
		9 th order	32,600		
		12 th order	20,000		
11.1:1	1000	3 rd order	46,600	455,000	182,000
		6 th order	119,800		
		9 th order	32,600		
		12 th order	20,000		

G3608 Rolling Torque (Full Load)					
Pressure Ratio	Speed (rpm)	Rolling Torque (lb-in)		Maximum Torque (lb-in)	Minimum Torque (lb-in)
9.2:1	900	4 th order	148,500	357,500	41,700
		8 th order	25,700		
		12 th order	21,600		
9.2:1	1000	4 th order	145,300	353,600	44,900
		8 th order	25,700		
		12 th order	21,600		
11.1:1	900	4 th order	202,700	433,700	1,000
		8 th order	38,700		
		12 th order	18,400		
11.1:1	1000	4 th order	199,000	429,700	4,300
		8 th order	38,700		
		12 th order	18,400		

G3606 Rolling Torque (Full Load)					
Pressure Ratio	Speed (rpm)	Rolling Torque (lb-in)		Maximum Torque (lb-in)	Minimum Torque (lb-in)
9.2:1	900	3 rd order	64,400	232,900	37,700
		6 th order	38,600		
		9 th order	16,100		
		12 th order	16,200		
9.2:1	1000	3 rd order	53,200	197,400	14,900
		6 th order	38,600		
		9 th order	16,100		
		12 th order	16,200		
11.1:1	900	3 rd order	74,300	261,900	32,400
		6 th order	54,200		
		9 th order	17,500		
		12 th order	8,500		
11.1:1	1000	3 rd order	44,400	230,000	43,000
		6 th order	54,300		
		9 th order	17,500		
		12 th order	8,500		

Part Load Strategy

The engine should be operated according to the following Part Load Strategy for minimum engine maintenance and maximum availability.

Engine Power	Time
0 – 30%	0.5 hrs
30 – 50%	2.0 hrs
50 + %	Continuous

Time represents the maximum hours of operation at the specified power before the engine must be run above 70 percent load for more than two hours.

Sound Power Data (Mechanical, Exhaust & Air Inlet)

Sound Power Data @ 900 rpm & 100% Load

Sound Data	Overall Sound Level db(A)	Sound Level in Linear Decibels (db) "Octave Band Center Frequency"									
		16 Hz	32 Hz	63 Hz	125 Hz	250 Hz	500 Hz	1 kHz	2 kHz	4 kHz	8 kHz
G3606											
Mechanical Sound	117.4	—	—	110.8	115.4	114.3	113.5	112.0	108.0	110.6	103.3
Exhaust Sound	132.2	—	125.7	128.6	125.7	119.1	117.1	120.8	125.1	129.4	127.9
Air Inlet Sound	127.7	—	106.7	114.8	113.4	112.9	110.8	111.4	118.0	123.4	123.6
G3608											
Mechanical Sound	123.3	98.7	103.6	114.4	112.5	111.9	112.9	114.9	117.7	117.7	114.3
Exhaust Sound	139.5	108.3	114.7	122.2	124.0	119.8	120.6	124.4	131.4	135.2	134.2
Air Inlet Sound	127.9	90.1	89.5	93.6	<90	90.3	100.8	105.8	110.8	123.7	123.9
G3612											
Mechanical Sound	124.0	95.4	109.2	118.8	113.5	112.9	114.5	116.8	118.6	117.6	113.6
Exhaust (Right) Sound	141.0	97.8	108.7	122.0	119.2	118.7	120.5	124.4	131.0	136.8	137.0
Exhaust (Left) Sound	124.9	93.4	109.3	122.1	121.6	114.3	110.3	120.7	114.9	114.9	118.2
Air Inlet (Left) Sound	124.2	<90	<90	<90	<90	<90	91.1	99.3	109.9	117.7	121.9
G3616											
Mechanical Sound	128.1	—	111.1	118.1	124.9	121.4	119.4	119.2	121.5	123.3	118.1
Exhaust (Right) Sound	144.6	—	117.3	122.2	128.6	124.4	125.3	129.0	134.7	139.8	139.0
Exhaust (Left) Sound	129.0	—	117.5	127.0	126.3	121.1	121.1	123.3	123.5	120.9	119.9
Air Inlet (Left) Sound	129.3	—	<100	<100	99.9	102.9	102.9	108.0	114.8	126.2	125.5

Data determined by methods similar to ISO Standard DIS-8528-10.
 Accuracy Grade 3.
 All numbers reflect sound power.
 Air Inlet sound is without engine air cleaner(s).

Sound Power Data @ 1000 rpm & 100% Load

Sound Data	Overall Sound Level db(A)	Sound Level in Linear Decibels (db) "Octave Band Center Frequency"									
		16 Hz	32 Hz	63 Hz	125 Hz	250 Hz	500 Hz	1 kHz	2 kHz	4 kHz	8 kHz
G3606											
Mechanical Sound	118.4	—	—	—	119.6	116.9	115.5	113.6	108.6	109.0	99.8
Exhaust Sound	136.6	—	119.2	130.3	127.2	122.2	119.9	123.1	128.8	133.3	131.4
Air Inlet Sound	127.0	—	104.4	113.8	115.8	115.0	112.9	112.0	117.4	122.6	123.0
G3608											
Mechanical Sound	125.4	103.8	108.9	113.8	114.0	112.8	114.9	116.0	119.8	120.3	115.9
Exhaust Sound	143.4	102.7	117.4	119.7	124.9	121.3	123.3	126.7	135.2	139.3	138.2
Air Inlet Sound	129.9	<90	<90	<90	<90	97.3	101.5	106.2	109.9	126.6	125.2
G3612											
Mechanical Sound	125.7	100.7	108.0	121.3	125.7	119.6	119.6	118.9	119.7	118.8	110.9
Exhaust (Right) Sound	143.6	101.6	107.9	122.9	121.0	120.5	122.5	127.5	132.8	139.0	140.3
Exhaust (Left) Sound	125.2	88.7	104.1	120.7	119.7	114.3	111.7	120.5	115.5	114.6	118.7
Air Inlet (Left) Sound	122.5	<90	<90	<90	<90	<90	93.4	<90	105.1	116.2	120.1
G3616											
Mechanical Sound	128.1	—	111.1	118.1	124.9	121.4	119.4	119.2	121.5	123.3	118.1
Exhaust (Right) Sound	144.6	—	117.3	122.2	128.6	124.4	125.3	129.0	134.7	139.8	139.0
Exhaust (Left) Sound	129.0	—	117.5	127.0	126.3	121.1	121.1	123.3	123.5	120.9	119.9
Air Inlet (Left) Sound	129.3	—	<100	<100	99.9	102.9	102.9	108.0	114.8	126.2	125.5
Data determined by methods similar to ISO Standard DIS-8528-10. Accuracy Grade 3. All numbers reflect sound power. Air Inlet sound is without engine air cleaner(s).											

Power Supply Requirements

System Description Metric (English)	G3606	G3608	G3612	G3616
Jacket Water Heater (Optional) kW (Btu/min)	18 (1024)	18 (1024)	30 (1706)	30 (1706)
Lube Oil Heater (Optional) kW (Btu/min)	9 (512)	9 (512)	9 (512)	9 (512)
Combination Jacket Water/Lube Oil Heater (Optional) kW (Btu/min)	18/9 (1024/512)	18/9 (1024/512)	18/9 (1024/512)	18/9 (1024/512)

Reference Materials

The following information is provided as additional reference to subjects discussed in this guide.

REN5908

Systems Operation, Testing and Adjusting (G3600 Engines)

SEBU7563

Operation & Maintenance Manual (G3600 Engines)

